

Owner's Manual & Operating Instructions

866 Challenger Series Rotary Vane Vacuum Pumps



Visit our web site to download pump setup guides,
brochures and other technical information.



866 Challenger

Owner's Record

Date of Purchase: _____

Purchased from: _____

Serial Number: _____

© 2009 National Vacuum Equipment, Inc.
March 2011

No part of this manual may be reproduced without the written permission of
National Vacuum Equipment, Inc.

IMPORTANT INFORMATION FOR INSTALLING PUMP

866 CHALLENGER SERIES PUMPS AERIAL VIEW

*SHADED AREA MUST BE KEPT CLEAR
FOR SERVICING THE FILTER*

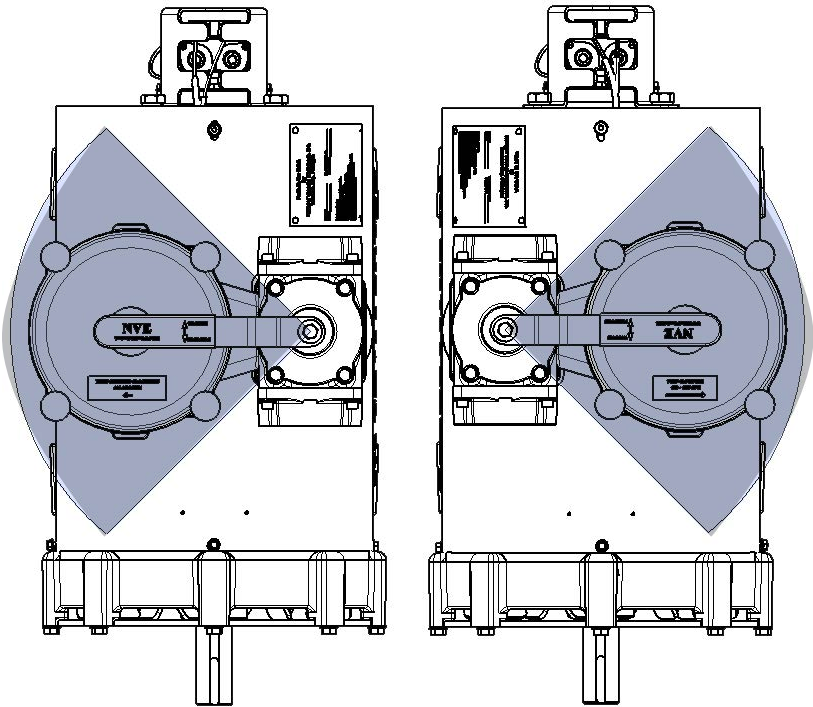

Counter Clockwise
Rotation

Clockwise
Rotation

CONTENTS

Introduction.....	5
General Information.....	5
Limited Warranty	6
Warranty	6
866 Challenger	10
Application	10
Pump Specifications	10
System Requirements	11
Drive System	12
Factory Settings	12
Adjusting Factory Oil Settings	13
Operating Instructions	14
Normal Operation	14
Recommended Lubricant	15
Maintenance	16
Cold Weather Operation.....	17
Troubleshooting	18
Pump overheats	18
Pump uses too much oil.....	18
Pump doesn't turn	18
No vacuum	19
System Troubleshooting.....	19
Making a Vacuum Tester	20
Parts Breakdown	22
Fan Parts List	22
Liquid Parts List.....	26
Oil Pump Parts List	29
Warranty Card	33

INTRODUCTION

General Information



About National Vacuum Equipment

Congratulations! You now own a quality vacuum/pressure pump proudly manufactured in the U.S.A. by National Vacuum Equipment, Inc. You have not only acquired a superior piece of equipment from a qualified dealer, you have hired a team of vacuum experts. We stand ready to work with your dealer to answer your questions and provide you with the information necessary to keep your equipment in peak working condition.

Thank you for using National Vacuum Equipment.

Our Mission

NVE is dedicated to the manufacture and wholesale distribution of quality vacuum system products at a reasonable price and delivered on a timely basis. NVE is a “one-stop shop” for manufacturers and distributors of vacuum equipment.

Our History

National Vacuum Equipment, Inc. was founded in 1980 by Bruce Luoma. NVE started as a retailer of vacuum pumps. Soon after it started, NVE secured the rights to exclusive distribution of the Battioni vacuum pumps in North America. This allowed NVE to evolve into its current status as a wholesale supplier.

To reach the goal of becoming a full service supplier of vacuum system components, NVE began fabrication its own line of componentry, purchased and developed its own line of vacuum pumps, and began purchasing for resale various valves and accessories.

Today, NVE has full service machine, fabrication and powder-coating shops complete with CNC-controlled production equipment designed for close tolerance work. Our staff is highly trained and are committed to quality from start to finish.

LIMITED WARRANTY

866 Challenger

Warranty

National Vacuum Equipment, Inc.

Guarantees that the product it provides is free of manufacturer's defects, including materials and workmanship. Properly installed and maintained product is warranted for a period of one (1) year subject to the following conditions:

1. A properly completed warranty registration card must be received by us within 30 days of sale to end user for pump sales to be considered warrantable. All pumps received for warranty consideration must retain the original NVE serial number tag.
2. The one (1) year period shall begin the day the product is shipped from our warehouse, unless we are provided with an authentic copy of the original resale invoice, in which case the one (1) year period shall begin at such invoice date.
3. The covered product must be used in an application for which it was intended. We do not recommend our product for particular uses or applications.
4. Vane breakage, or damage caused by vane breakage, is not warrantable.
5. Damage caused by improper use or lack of proper maintenance is not warrantable.
6. Manufacturer's liability under this or any other warranty, whether express or implied, is limited to repair of or, at the manufacturer's option, replacement of parts which are shown to have been defective when shipped.

7. Manufacturer's liability shall not be enforceable for any product until National Vacuum Equipment, Inc. has been paid in full for such product.
8. Except to the extent expressly stated herein, manufacturer's liability for incidental and consequential damage is hereby excluded to the full extent permitted by law.
9. Manufacturer's liability as stated herein cannot be altered except in writing signed by an officer of National Vacuum Equipment, Inc.
10. Certain products provided by National Vacuum Equipment, Inc. are covered by their respective manufacturer's warranties (e.g., engines used in the NVE engine drive packages). These products are not covered by the National Vacuum Equipment, Inc. Manufacturer's Warranty.
11. Final assemblers responsibility. NVE goes to great lengths to insure the quality and proper functionality of the products it supplies. Many products we supply are purchased for resale or are impossible or impractical to test prior to the installation of the item in a vacuum system. It is therefore the responsibility of the final assembler to thoroughly test the vacuum system and components supplied to the assembler by NVE prior to the delivery of the final product to the end user.

Any items found to be defective after delivery to the end user that should have been discovered prior to delivery will qualify replacement of the defective part only with absolutely no compensation for outside labor or travel expenses. Any subsequent damage to other components caused by the defective part will be the sole responsibility of the assembler.

WARRANTY PROCEDURES

Should a potential warranty situation arise, the following procedures must be followed:

- Contact your dealer or NVE immediately upon the occurrence of the event and within the warranty period.
- Customer must receive a return goods authorization (RGA) before returning product.
- All serial-numbered products must retain the NVE serial number tag to be qualified for warranty.
- Product must be returned to NVE intact for inspection before warranty will be honored.
- Product must be returned to NVE freight prepaid in the most economical way.
- Credit will be issued for material found to be defective upon our inspection, based upon prices at the time of purchase.

866 Challenger

Model-Specific Information

Application

Designed for extended operation

- Duty cycle will vary depending on several factors, such as altitude, RPM & ambient temperature.
- The 866 Challenger is a severe duty vacuum pump, designed to be used in liquid waste pumping systems where extended operation is desired.
- Proven applications are:
 - Oil field
 - Restaurant Grease
 - Septic
 - Industrial Waste

Pump Specifications

866 Calculated Flow Data

RPM		Pressure (PSI)				Free Flow	Vacuum (in Hg)					
		20	15	10	5	0	6	12	15	18	21	27
1150	Hp	43	36	27	25	18	21	23	24	25	25	29
	CFM	431	438	447	457	519	470	453	440	438	425	351
1000	Hp	38	32	24	20	15	18	20	21	22	23	25
	CFM	375	381	389	398	452	409	394	390	381	370	306
800	Hp	32	25	19	15	13	14	16	17	18	19	21
	CFM	319	324	331	342	385	348	333	331	324	315	242

System Requirements

High Quality Components

- The 866 Challenger is a high performance vacuum pump and requires compatible, high quality components as manufactured by NVE.

Shutoffs

- We recommend the use of our Parts F-802C portal/portal shutoff, and our Part #F-901-C, 12 gallon scrubber/secondary shutoff.

Final filter

- We also require the use of a final filter. You can use our remote mounted filter. (Part #F-1001C)

Hose

- Use 4" or larger hose to pump your system. We recommend you use a hose that can withstand high temperatures such as hot tar-asphalt hose.

Pressure relief and vacuum relief valves

- A pressure relief valve and vacuum relief valve should also be incorporated in the system.
- The pressure relief valve should be set for a maximum of 25 p.s.i. or as allowed by the tank manufacturer if lower.
- The vacuum relief valve should be set for 20" Hg.
- The relief valves should be set to where the pump operates as a maximum temperature of 350 degrees F.

Drive System ---

- The pump should be mounted on a level, horizontal surface, secured with grade 5 or better fasteners.
- The drive system should be sized to supply the required horsepower to the pump plus a reserve to insure long life.
- Make certain that all shafts, pulleys or turning parts are properly guarded.
- Check the ratio of the drive system prior to installation to verify that the pump will be turning at the proper speed and direction.
- The pump should be set up to engage slowly to avoid initial torque damage.

Direction of Rotation ---

- The direction of rotation and RPM are marked on the front of the pump.
- The direction of rotation required by your drive system should be determined prior to ordering the pump.
- If during assembly of your unit you find you need the opposite rotation, call the factory for instructions.

Factory Settings ---

- The automatic lubrication pumps are set at the factory during pump testing and should require no further adjustment during pump installation. The pumps are adjusted to one drop every two seconds per outlet. This oil rate equals 2.7fluid oz. per hour or approximately 8hr./Gal.
- It is the responsibility of the installer to ensure proper vacuum and pressure settings and RPM.

Adjusting Factory Oil Settings ---

The automatic oil pump is a metered piston-type pump. If you wish to adjust the pump, please follow these instructions.

Adjusting the Oil Rate _____

1. To adjust the oil rate, remove cap #P16. Under this cap you will find a jam nut #P15 and adjusting screw #P11.
2. To adjust oil rate loosen jam nut and turn adjusting screw clockwise to reduce oil flow or counterclockwise to increase oil flow.
3. When making adjustments do so one turn of the screw at a time and test before making further adjustments.
4. Be careful to not turn adjusting screw to far counterclockwise as you may disengage the gears and strip them out and measure the oil required to replenish the tank (this should be 12oz - 15oz per hour).

Testing Flow Rate After Adjustment _____

1. Disconnect the hose running from your remote oil reservoir to the pump intake.
2. Oil flow is changed by adjusting the length of the stroke of the piston.
3. To adjust the oil rate, remove cap #P16. Under this cap you will find a jam nut #P15 and adjusting screw #P11
4. Loosen the jam nut and turn adjusting screw clockwise to reduce oil flow or counterclockwise to increase oil flow.
5. When making adjustments do so one turn of the screw at a time and test before making further adjustments.

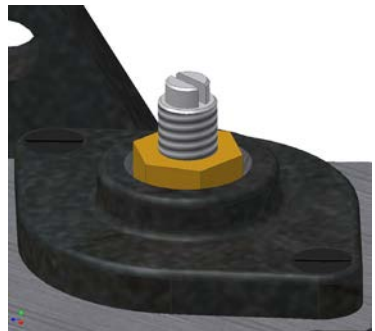

OPERATING INSTRUCTIONS

866 Challenger

Normal Operation

Oil Reservoir

- Check oil reservoir daily and fill as required.
- Drain and clean periodically depending on service.
- Clean the ballast air filter with diesel fuel regularly

Recommended RPM

- Do not operate the pump faster than the recommended rpm of 1000. 1150 RPM is for intermittent use only.
- Too low of an RPM can cause the vanes to clatter (inconsistent contact with the housing) causing wear.

Suction Valve

- To operate the suction valve, move the handle in the appropriate direction for either vacuum or pressure; center is neutral.

Vacuum Levels

- Do not operate your pump for extended periods of time at vacuum levels which cause the pump to exceed 375 degrees Fahrenheit exhaust gas temperature.

Guards

Make certain all guards are in place prior to running your pump.
Think Safety!

Recommended Lubricant _____

- We recommend that turbine oil be used in our pumps. Turbine oil is much more resistant to breakdown due to heat than normal motor oil, thereby avoiding the problems associated with motor oil such as lacquering and excessive wear.

Acceptable oils include:

1. * NVE ISO 68 Oil
2. Penzoil Penzabell 68 T.O.
3. Shell Turbo 68
4. Mobil D.T.E. Heavy - Medium
5. Texaco Regal R & O 68

* NVE ISO 68 Oil is our recommended pump oil for the Challenger series vacuum pumps. Challenger Vacuum Pump Oil is sold by the case, six-1 gallon containers of oil per case.

Ballast Cooling _____

- Ballast cooling of a vacuum pump is accomplished by introducing atmospheric air into the exhaust side of the pump housing. The ballast inlet is located at a point where the affected pump cell is no longer in contact with the intake port.
- The result is cooling of the housing and rotor with no appreciable drop in vacuum level.

Maintenance

Washing

- Periodically wash the mud and dirt off of your pump as it must be clean to allow heat to radiate from it.

Flushing

We recommend periodic flushing of your pump. To do this:

1. Connect the hose to the flush valve located on the side of the inlet port.
2. Put the end of the hose in a one pint container of diesel fuel. Start your pump and run as slow as possible.
3. With the 4-way valve in the vacuum position, open the flush valve and monitor the diesel flow to your pump.
4. When the diesel fuel is gone, switch the 4-way valve to neutral and run the pump for 2 minutes.
5. Speed the pump up to normal RPM, switch the 4-way valve to vacuum.
6. Remove the hose and close the valve.
7. Properly dispose of used oil and flushing fluid.

Checking Vane Wear

We recommend checking vane wear at least every 12 months.

- A new vane is flush with the outside diameter of the rotor.
- Remove the plug from the vane check port, insert a rod to rotor O.D., rotate rotor until the rod falls into one of the vane slots. If the rod falls more than a 1/4" into any of the 6 vane slots, it's time to replace the vanes.
- Vanes should be replaced in sets and it is always a good idea to have an extra set of vanes on hand for emergencies.

Cold Weather Operation _____

Confirm pump is not frozen

- Prior to engaging the pump, turn by hand to confirm it is not frozen.

If pump is frozen, thaw it.

- If the pump is frozen, move the truck into a heated building.

Avoid freezing problems

- You can avoid freezing problems by putting a small amount of diesel fuel into the pump at the end of the day.

TROUBLESHOOTING

NVE 866 Vacuum Pump

Pump overheats _____

- No oil in pump
- Oil adjustment set too lean
- RPM too fast
- Prolonged operation at excessive vacuum or pressure levels,
- Pump is dirty
- Ballast filter is clogged or dirty.

Pump uses too much oil _____

- Oil pump set too rich
- Leaving pump under vacuum between jobs
- Product running through pump

Pump doesn't turn _____

- Broken vane or bearing
- Pump is frozen
- Problem in the drive train

No vacuum

- Suction valve is in neutral
- Worn seals or vanes
- Pump is not turning fast enough
- Check valve or suction valve is clogged
- Leak in the tank or fittings
- Collapsed hose between the pump and shutoffs
- Ballast filter clogged

System Troubleshooting

Locating the source of the trouble

If you notice a decrease in pump performance, start troubleshooting at the pump.

- Remove the suction and discharge hoses at the pump
- Start the pump and run it in vacuum only at its normal rpm
- Check the vacuum level at the pump inlet. The 866 Challenger in new condition will develop 27-28.5" hg.
- If the pump checks out ok, check the vacuum level at the secondary, then the primary shutoff. Keep working your way back until you find the problem.

For rebuild instructions please visit our website at www.nvepump.com or call us at 800-253-5500.

Making a Vacuum Tester

1. Procure a flange to mount on your four-way valve, a short 4" pipe nipple, a 4" pipe cap and a vacuum gage.
2. Drill and tap a 1/4" N.P.T. thread in the pipe cap.
3. Assemble the flange, nipple, pipe cap and vacuum gage.
4. Remove a flange from the four-way valve on your pump.
5. Start the pump and confirm the location you have chosen to test from is at vacuum.
6. Using the existing O-ring, fasten the testing flange to your pump.
7. Start your pump and read the vacuum level on the gauge.

NVE 866 Challenger Fan Cooled | Parts Diagram

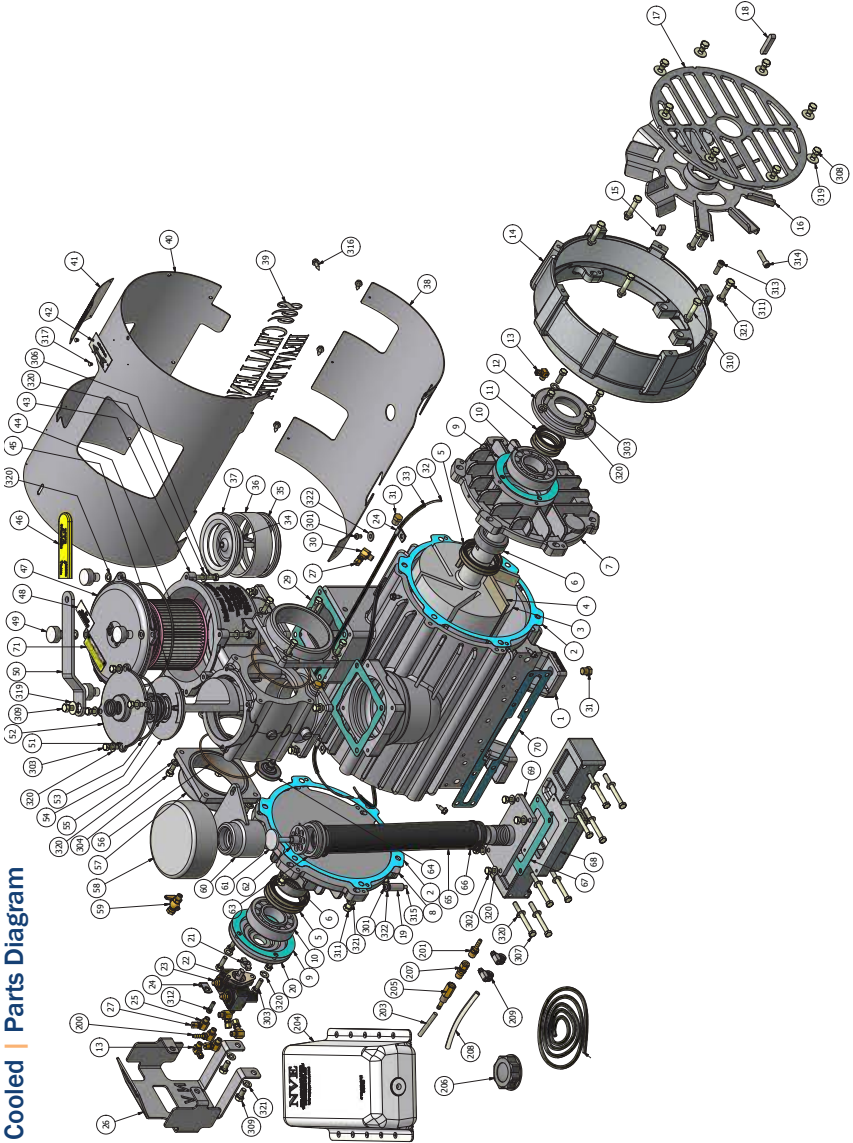

NVE 866 Challenger - Fan Cooled Parts Breakdown

ITEM	QTY	PART NUMBER	DESCRIPTION
1	1	120-001-506	HOUSING, 466
2	2	120-004-460	GASKET, END PLATE 460
3	1	120-005-506-D 120-005-506-S	ROTOR, 506 CW ROTOR, 506 CCW
4	6	120-007-506	VANE: 506
5	4	120-018-506	SEAL, 65 X 85 X 8 VITON
6	2	120-009-506	Seal Sleeve, 460, 466 & 506
7		120-003-506-D	ENDPLATE, GEN 466 & 506
8	1	120-003-506-S	ENDPLATE, GEN 466 & 506
9	2	120-055-506	GASKET, BEARING COVER
10	2	120-019-506	BEARING, NJ309
11	2	120-053-506	SEAL, 45X62X8 VITON
12	1	120-054-506	BEARING COVER
13	2	320-408-005	FITTING, ELBOW 1/8 NPT-TUBE
14	1	120-074-506	FAN SHROUD, 466/506/866
15	1	120-076	KEY, 3/8" X 3/8" X 1"
16	1	120-084-002 210-084-001	FAN ASSY, CW, 866 FAN ASSY, CW, 866
17	1	120-073	FAN GUARD, 367, 460, 466 & 506
18	1	120-006	KEY, 3/8" X3/8" X 2
19	1	120-077-506	SHROUD SUPPORT
20	1	120-080-506	BEARING COVER, 506 OIL PUMP
21	1	320-LF8	DRIVE TAB
22	1	320-R31	GASKET, OIL PUMP
23	1	320-LW32-BD 320-LW32-BS	OIL PUMP, 4 PORT CW OIL PUMP, 4 PORT CCW
24	3	320-409-003	P-CLIP, OIL LINE 1/4" X 5/16
25	4	320-408-001	ADAPTER, ELBOW 1/8 BSPTM-NTPF
26	1	120-079-002	GUARD, OIL PUMP 866
27	6	320-408-004	FITTING, STRT 1/8 NPT-TUBE
28	1	320-006	FITTING, ELBOW 1/4" OD X 1/8" NPTF WORLD
29	2	120-039-506	GASKET, 4" INT/EXH FLANGE
30	2	320-408-002	ADAPTER, ELBOW 1/8 MNPT-FNPT
31	4	120-059	PLUG, BRASS 1/4" NPT, HEX HD.
32	6.458	320-407-001	OIL LINE, 1/8" OD PFA
33	5.792	320-409-002	OIL LINE PROTECTOR, 1/4" FIBERGLASS
34	1	120-041-506	CHECK VALVE, 4"
35	1	120-042-506	RETAINER, 4" CHECK VALVE
36	1	120-041-001	INTERNAL CHECK VALVE, BODY, 866
37	1	120-041-002	INTERNAL CHECK VALVE, TOP PLATE, 866
38	1	120-070-506-D	SHROUD, LOWER
39	1	120-100-866	DECAL, 866 CHALLENGER HD
40	1	120-071-506-D	SHROUD, UPPER
41	1	120-105	TAG, LARGE, NVE SERIAL NUMBER
42	1	120-106-367-D 120-106-367-S	PLATE , CW PLATE, CCW
43	1	120-320-002	MANIFOLD, 866, MACHINED
44	1	120-314-001	FILTER ELEMENT, 60 MESH
45	1	120-064-004	O-RING, 2-265 VITON
46	1	120-060-002	GRIP, HANDLE W/ LOGO
47	1	120-310-001	COVER, FILTER 607/866
48	1	120-101-506-D 120-101-506-S	DECAL, RPM-CW 506/866 DECAL, RPM-CCW 506/866
49	4	120-312-002	KNOB, 5/16-18UNC
50	1	120-060-001	HANDLE, 367 GEN 2

NVE 866 Challenger - Fan Cooled Parts Breakdown - *Continued*

ITEM	QTY	PART NUMBER	DESCRIPTION
51	2	120-064-002	O-RING, 2-214 VITON
52	1	120-065-001	TOWER, 866, MACHINED
53	1	120-064-007	O-RING, 2-248 VITON
54	1	120-045	4-WAY FV SPRING (COMPRESSED)
55	1	120-062-006	PLUG, 866, MACHINED
56	2	120-064-506	O-RING, 2-158 SILICONE
57	2	120-063-506	FLANGE, 4" NPT
58	1	120-099-506-4	BALLAST FILTER ASSEMBLY, REMOTE
59	1	120-102	VALVE, DRAIN 1/8" NPT
60	1	120-099-001	CHECK VALVE BODY, ASSEMBLY
61	1	120-099-002	CHECK VALVE, 1 1/2" POPPIT ASSEMBLY
62	1	120-099-003	CHECK VALVE, 1 1/2", POPPIT GUIDE
63	1	120-099-004	CHECK VALVE, 1 1/2", BARB END
64	1	120-220	THERMOMETER, 50- 400 DEG, 2" FACE, 2.5" STEM, 1/4" - 18NPT
65	1.25	426-150-TAR	HOSE, 1.5" OD, HOT TAR AND ASPHALT
66	2	416-100-1WC	CLAMP, WORM, 1"-2" DIA
67	1	120-097-506-E	GASKET, BALLAST ELBOW
68	1	120-090-506	LOWER BALLAST MANIFOLD
69	1	120-041-017	BALLAST PORT, HOSE CONNECTION WELDMENT
70	1	120-097-506-M	GASKET, LOWER BALLAST MANIFOLD
71	1	120-103-367	DECAL, IMPORTANT 375F
200	1	310-LP5	HOSE BARB TO MALE PIPE
201	1	310-LP6	HOSE BARB, 1/4 TO 1/4NPT STRT
202	5	320-407-003	OIL LINE, BLK 1/4" ID 30R7
203	1	320-083-009	OIL TANK FILTER, 100 MESH
204	1	320-082-001	OIL TANK, 5QT, W/LOGO
205	1	320-083-010	FILTER FITTING, OIL TANK 1/4 NPT
206	1	320-083-002	CAP, OIL TANK, BLACK 2 1/4"
207	1	320-408-010	FITTING, 1/4" TUBE X 1/4" MNPT
208	1	320-R102-6IN	OIL LINE, 3/8" X 1/4" ID X 6" LG
209	2	416-025-1WC	CLAMP, WORM, .250" DIA
301	6	HHCS - 5/16-18 UNC x 0.75	HHCS - 5/16-18 UNC X 0.75
302	2	SHCS - 5/16-18 UNC X 0.875	SHCS - 5/16-18 UNC X 0.875
303	10	HHCS - 5/16-18 UNC x 1	HHCS - 5/16-18 UNC X 1
304	16	HHCS - 5/16-18 UNC X 1.25	HHCS - 5/16-18 UNC X 1.25
305	4	HHCS - 5/16-18 UNC X 2 FT	HHCS - 5/16-18 UNC X 2 FULL THREAD
306	3	HHCS - 3/8-16 UNC x 0.75	HHCS - 3/8-16 UNC X 0.75
307	8	HHCS - 3/8-16 UNC X 1.50	HHCS - 3/8-16 UNC X 1.50
308	2	SHCS - 1/4-20 UNC X 0.75	SHCS - 1/4-20 UNC X 0.75
309	9	FW - 3/8 USS	FLAT WASHER - 3/8 USS
310	48	LW - 5/16	LOCK WASHER, 5/16
311	14	LW - 3/8	LOCK WASHER, 3/8"
312	8	HHCS - 5/16-18 UNC X 3.25	HEX CAP SCREW - 5/16-18 UNC X 3.25
313	8	HHCS - 3/8-16 UNC X 0.50	HHCS - 3/8-16 UNC X 0.50
314	4	HHCS - 3/8-16 UNC X 2.00	HHCS - 3/8-16 UNC X 2.00
315	1	SHCS - 5/16-24 UNF X 1.25	SHCS - 5/16-24 UNF X 1.25
316	1	HSSS - 1/4-20 UNC X 0.75	HEX SOCKET SET SCREW 1/4-20 UNC X 0.75
317	7	TAPSCR - 1/4-14 X 0.75	HEX HEAD SELF TAPPING SCREW 1/4-14
318	6	RVT 1/8 D X 1/8L	BLIND RIVET, 1/8 DIA X 1/8 GRIP, ALUM
319	2	FW - 1/4 USS	FLAT WASHER - 1/4" USS
320	2	BHCS - 1/4-20 UNC X 0.38	BHCS - 1/4-20 UNC X 0.38

Notes

NVE 866 Challenger Liquid Cooled | Parts Diagram

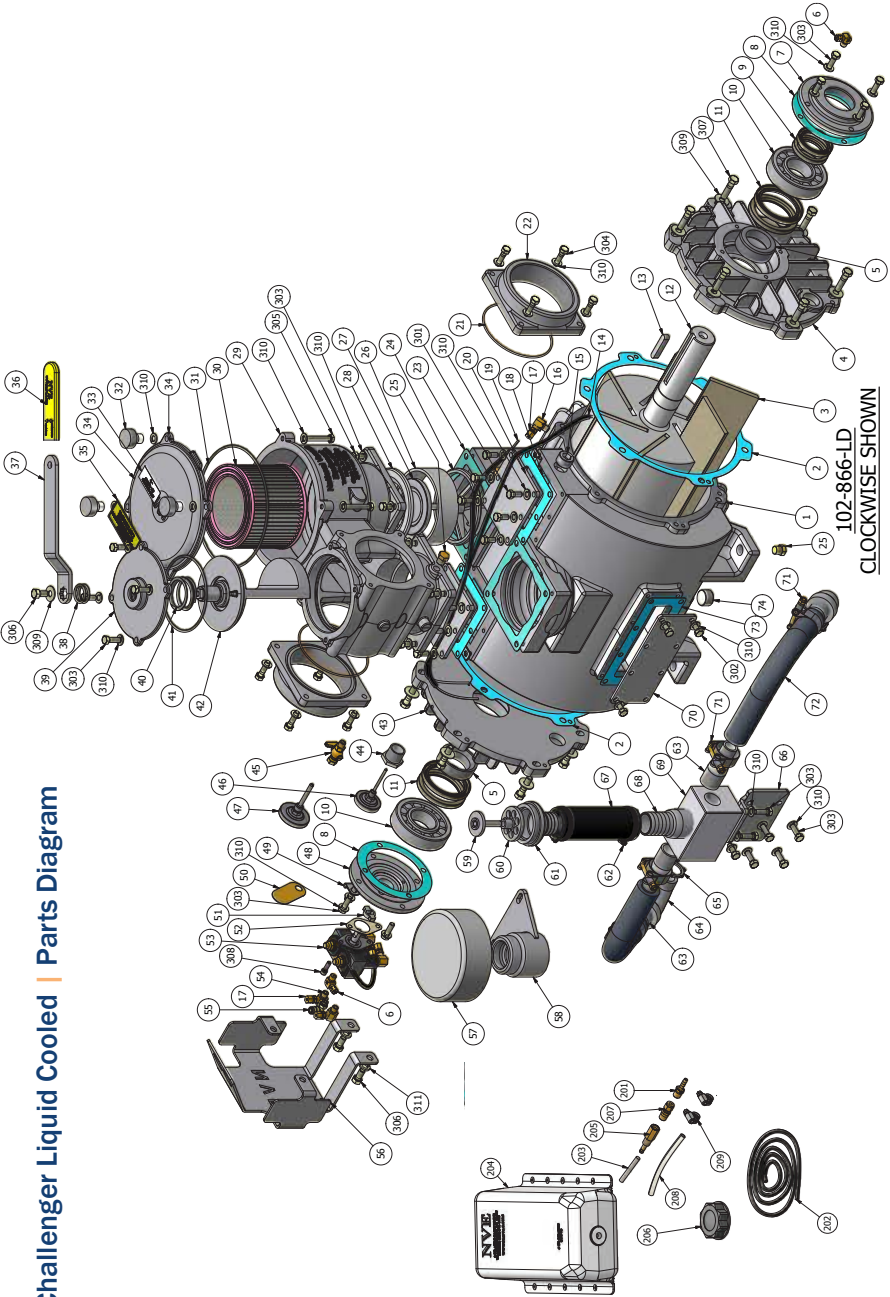

NVE 866 Challenger - Liquid Cooled Parts Breakdown

ITEM	QTY	PART NUMBER	DESCRIPTION
1	1	120-001-506-L	HOUSING, 506 LIQUID COOLED
2	2	120-004-460	GASKET, END PLATE 460
3	6	120-007-506	VANE: 506
4	1	120-003-506-LD	END PLATE, GEN 477 & 506
5	2	120-009-506	SEAL SLEEVE, 460, 466 & 506
6	2	320-408-005	FITTING, ELBOW 1/8 NPT-TUBE
7	1	120-054-506	BEARING COVER
8	2	120-055-506	GASKET, BEARING COVER
9	2	120-053-506	SEAL, 45" X 62" X 8" VITON
10	2	120-019-506	BEARING, NJ309
11	2	120-018-506	SEAL, 65" X 85" X 8" VITON
12	1	120-005-506 D/S	ROTOR, 506 CW OR CCW
13	1	120-006	KEY, 3/8" X 3/8" X 2"
14	5.78	320-409-002	OIL LINE PROTECTOR, 1/4" FIBERGLASS
15	3	120-047	DRAIN PLUG, 3/4 NPT
16	2	320-408-002	ADAPTER, ELBOW 1/8 MNPT-FNPT
17	6	320-408-004	FITTING, STRT 1/8 NPT-TUBE
18	2	120-022-506	GASKET, 506 TOP COVER PLATE
19	6.44	320-407-001	TUBE, 1/8" OD PFA
20	2	120-039-506	GASKET, 4" INT/EXT FLANGE
21	2	120-064-506	O-RING, 2-158 SILICONE
22	2	120-063-506	FLANGE, 4" NPT
23	2	120-039-506	GASKET, 4" INT/EXT FLANGE
24	1	120-042-506	RETAINER, 4" CHECK VALVE
25	4	120-059	PLUG, BRASS 1/4": NPT, HEX HD.
26	1	120-041-001	INTERNAL CHECK VALVE, BODY, 866
27	1	120-041-506	CHECK VALVE, 4"
28	1	120-041-002	INTERNAL CHECK VALVE, TOP PLATE, 866
29	1	120-320-002	MANIFOLD, 866, MACHINED
30	1	120-314-001	FILTER ELEMENT, 60 MESH
31	1	120-064-004	O-RING, 2-265 VITON
32	4	120-312-002	KNOB, 5/16-18UNC
33	1	120-101-506-D 120-101-506-S	DECAL, RPM-CW 506/866 (102-866-LD) DECAL, RPM-CCW 506/866 (102-866-LS)
34	1	120-310-001	CVER, FILTER RM
35	1	120-103-367	DECAL, IMPORTANT 375F
36	1	120-060-002	GRIP, HANDLE W/LOGO
37	1	120-060-001	HANDLE, 367 GEN 2
38	2	120-064-002	O-RING, 2-214 VITON
39	1	120-065-001	TOWER, 866, MACHINED
40	1	120-045	4-Way FV SPRING (COMPRESSED)
41	1	120-064-007	O-RING, 2-248 VITON
42	1	120-062-006	PLUG, 866, MACHINED
43	1	120-003-506-LS	END PLATE, GEN 466 & 506
44	1	120-049	BUSHING, 3/4" NPT X 1/8" NPT
45	1	120-102	VALVE, DRAIN 1/8 NPT
46	1	120-220-1	1/8" NPT THERMOMETER 220 F
47	1	120-220	THERMOMETER, 50- 400 DEG, 2" FACE, 2.5" STEM, 1/4" - 18NPT
48	1	120-080-506	BEARING COVER, 506 OIL PUMP
49	4	320-409-003	P-CLIP, OIL LINE 1/4" X 5/16"
50	1	120-107	TAG, SERIAL NUMBER, BRASS

NVE 866 Challenger - Liquid Cooled Parts Breakdown - *Continued*

ITEM	QTY	PART NUMBER	DESCRIPTION
51	1	320-LF8	DRIVE TAB
52	1	320-R31	GASKET, OIL PUMP
53	1	320-LW32-BD 320-LW32-BS	OIL PUMP, 4 PORT CW (102-866-LD) OIL PUMP, 4 PORT CCW (102-866-LS)
54	5	320-408-001	ADAPTER, ELBOW 1/8 BSPTM-NTPF
55	1	310-LP5	1/4" HOSE BARB X 1/8" NPT STRAIGHT
56	1	120-079-002	GUARD, OIL PUMP 866
57	1	120-099-506-4	BALLAST FILTER ASSEMBLY, REMOTE
58	1	120-099-001	CHECK VALVE BODY ASSEMBLY
59	1	120-099-002	CHECK VALVE 1 1/2", POPPET ASSEMBLY
60	1	120-099-003	CHECK VALVE 1 1/2", POPPET GUIDE
61	1	120-099-004	CHECK VALVE 1 1/2", BARB END
62	2	416-100-1WC	CLAMP, WORM, 1"-2" DIA
63	4	440-100	NIPPLE, KING 1" NPT
64	2	428-100-E	STREET ELBOW
65	2	CPF-1.00D	1" CONDUIT LOCKNUT
66	1	120-088-506	BRACKET BALLAST BLOCK, LIQUID
67	0.5	426-150-TAR	HOSE, 1.5" TAR AND ASPH
68	1	428-150-KN	1/2 KING NIPPLE, 1.5" NPT STEEL PL
69	1	120-089-866	BALLAST BLOCK 866 LIQ COOLED
70	1	120-021-367	COVER PLATE, 367 WATER JACKET
71	4	120-015	CLAMP, T-BOLT 1.5"
72	2	440-016-PF	HOSE, HYDRAULIC, 1.00"
73	1	120-022-376	GASKET, 367/506 COVER PLATE
74	1	120-047-1	DRAIN PLUG, 3/4" NPT MAGNETIC
200	1	310-LP5	HOSE BARB TO MALE PIPE
201	1	310-LP6	HOSE BARB, 1/4 TO 1/4NPT STRT
202	5	320-407-003	OIL LINE, BLK 1/4" ID 30R7
203	1	320-083-009	OIL TANK FILTER, 100 MESH
204	1	320-082-001	OIL TANK, 5QT, W/LOGO
205	1	320-083-010	FILTER FITTING, OIL TANK 1/4 NPT
206	1	320-083-002	CAP, OIL TANK, BLACK 2 1/4"
207	1	320-408-010	FITTING, 1/4" TUBE X 1/4" MNPT
208	1	320-R102-6IN	OIL LINE, 3/8" X 1/4" ID X 6" LG
209	2	416-025-1WC	CLAMP, WORM, .250" DIA
301	14	HHCS - 5/16-18 UNC x 0.75	HHCS - 5/16-18 UNC x 0.75
302	4	HHCS - 5/16-18 UNC X 0.875"	HHCS - 5/16-18 UNC X 0.875"
303	24	HHCS - 5/16-18 UNC x 1	HHCS - 5/16-18 UNC x 1
304	8	HHCS - 5/16-18 UNC X 1.25	HHCS - 5/16-18 UNC X 1.25
305	4	HHCS - 5/16-18 UNC X 2 FT	HHCS - 5/16-18 UNC X 2 FULL THREAD
306	3	HHCS - 3/8-16 UNC x 0.75	HHCS - 3/8-16 UNC x 0.75
307	12	HHCS - 3/8-16 UNC X 1.50	HHCS - 3/8-16 UNC X 1.50
308	2	SHCS - 1/4-20 UNC X 0.75	SHCS - 1/4-20 UNC X 0.75
309	13	FW - 3/8 USS	FLAT WASHER - 3/8 USS
310	58	LW - 5/16	LOCK WASHER, 5/16
311	2	LW - 3/8	LOCK WASHER, 3/8"

Detail - Key # 26
Automatic Oil Pump

Three Outlet Type

Part # 320 - LW32AD Clockwise
Part # 320 - LW32AS Counterclockwise

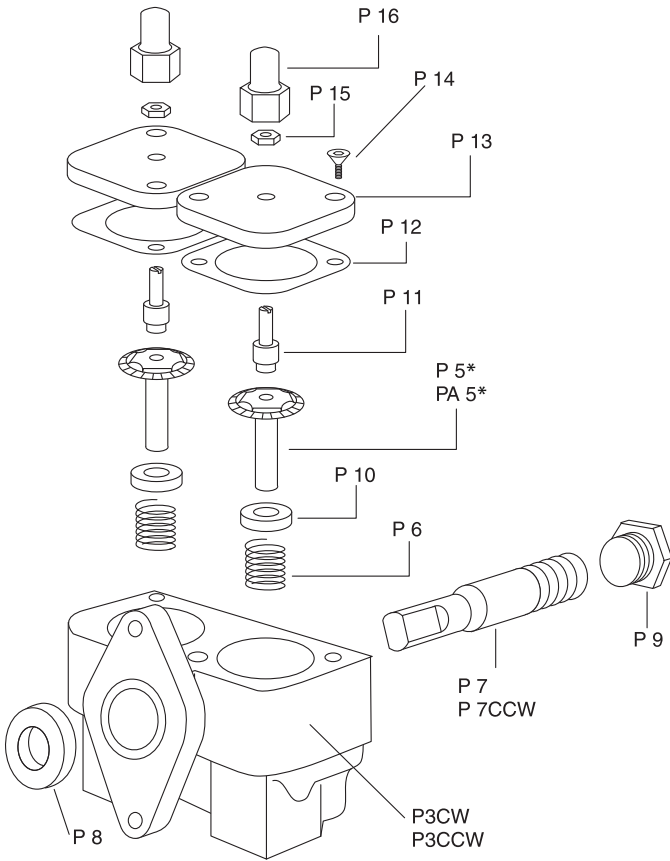

Parts List – Automatic Oil Pump

See Parts Diagram Opposite.

Part #	Description
320-P3CW	Pump Body (Clockwise)
320-P3CCW	Pump Body (Counterclockwise)
320-P5	Driven Gear (Clockwise)
320-PA5	Driven Gear (Counterclockwise)
320-P6	Spring
320-P7	Driving Gear (Clockwise)
320-P7CCW	Driving Gear (Counterclockwise)
320-P8	Seal
320-P9	Plug
320-P10	Retainer
320-P11	Adjusting Screw
320-P12	Gasket
320-P13	Lid
320-P14	Screw
320-P15	Jam Nut
320-P16	Cap

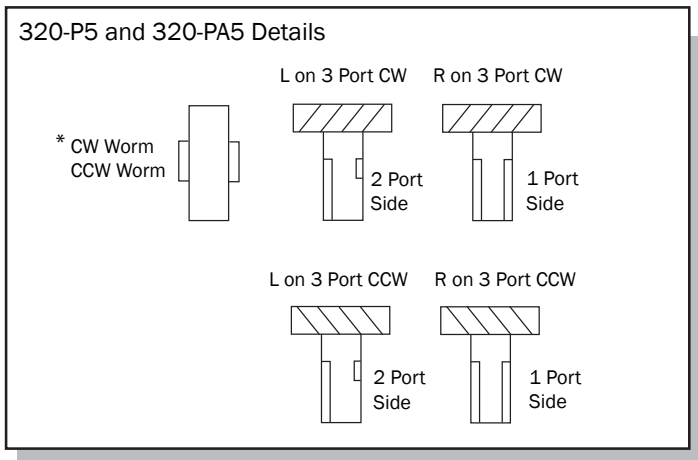

Detail - Key # 26

Automatic Oil Pump

Four Outlet Type

Part # 320-LW32BD Clockwise
Part # 320-LW32BS Counterclockwise

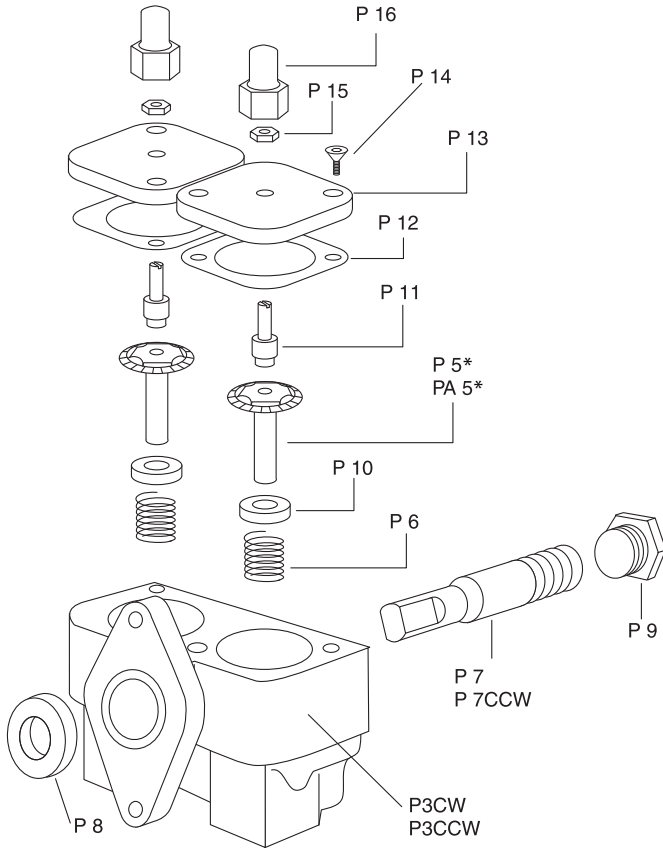

Parts List – Automatic Oil Pump

See *Parts Diagram Opposite*.

This oil pump is in all pumps with a Serial # that is 31845 or above.

Part #	Description
320-P4CW	Pump Body (Clockwise)
320-P4CCW	Pump Body (Counterclockwise)
320-P5	Driven Gear (Clockwise)
320-PA5	Driven Gear (Counterclockwise)
320-P6	Spring
320-P7	Driving Gear (Clockwise)
320-P7CCW	Driving Gear (Counterclockwise)
320-P8	Seal
320-P9	Plug
320-P10	Retainer
320-P11	Adjusting Screw
320-P12	Gasket
320-P13	Lid
320-P14	Screw
320-P15	Jam Nut
320-P16	Cap

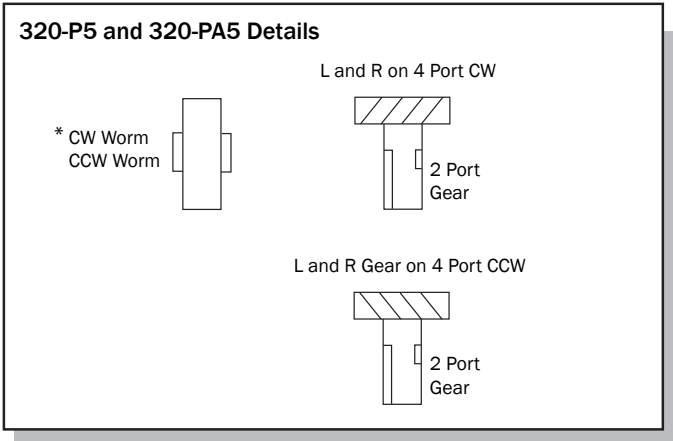

NVE

National Vacuum Equipment, Inc.

P.O. Box 685
Traverse City, MI 49685 USA

231.941.0215 Phone
231.941.2354 Fax

800.253.5500 | www.natvac.com