

# Pro Pack

## Engine Driven Systems

Masport have been manufacturing vacuum/pressure pumps and systems for over 100 years, so you can be sure of engineering excellence.

The Masport range of Pro Pack Engine Driven Systems are specifically designed and engineered for slide-in tanks and smaller tank trucks.

Each system is made with an electric start Honda Motor, solid steel base, oil system and quality Masport pump to ensure you will have no worries for years to come. Its compact design ensures an easy installation, saving you time and money - Simply bolt down and connect to your tank!

Every system is factory tested before shipping and is backed up by a one year warranty against all manufacturing defects.

With Masport on board you have an efficient and reliable pump and system backed by the best service and support that has made Masport the #1 choice for pumpers worldwide.

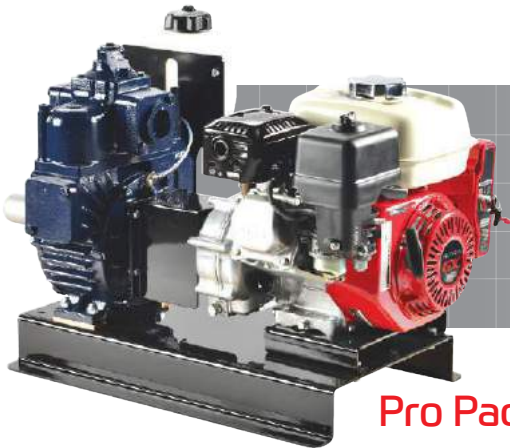

**Pro Pack 750**

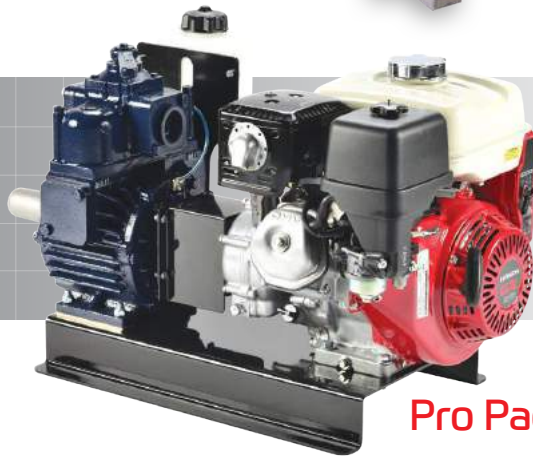

**Pro Pack 1000**

Direct Drive

Belt Drive

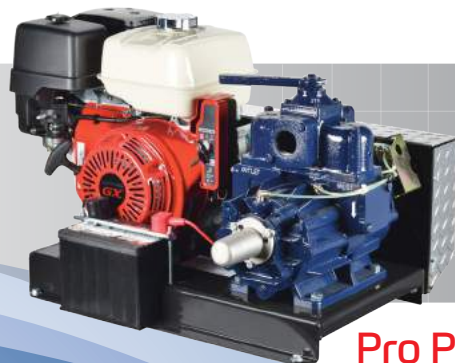

**Pro Pack 1500**



**Pro Pack 2500**



# Pro Pack 750

- ▶ Designed for tank sizes up to 750 Gallons
- ▶ Available in 5.5 Hp and 9 Hp Honda Engines
- ▶ 76 CFM HXL2V Pump
- ▶ 20" Hg Continuous Duty
- ▶ 5-10 PSI Continuous Duty
- ▶ Electric Start
- ▶ 2:1 Direct Drive Gearbox – no belts to squeal, slip or replace
- ▶ Integrated Oil Reservoir
- ▶ Built-in centrifugal clutch – allows for better horsepower transfer and the engine to idle without having the pump running
- ▶ Available in both vacuum/pressure or vacuum only model

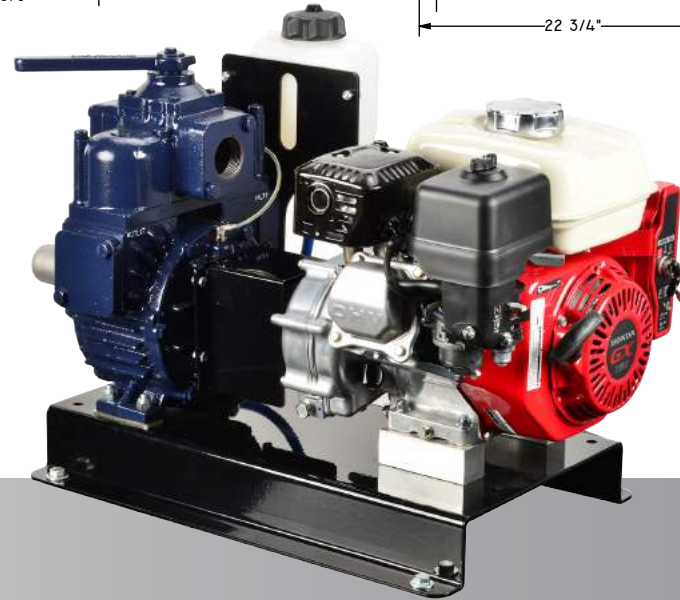
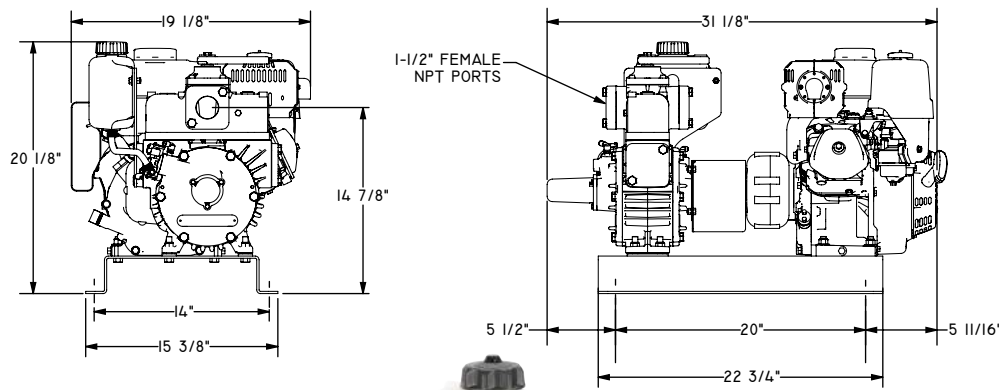

# Pro Pack 1000

- ▶ Designed for tank sizes up to 1000 Gallons
- ▶ Made with a 9 Hp Honda Engine
- ▶ 106 CFM HXL3V Pump
- ▶ 20" Hg Continuous Duty
- ▶ 10 PSI Continuous Duty
- ▶ Electric Start
- ▶ 2:1 Direct Drive Gearbox – no belts to squeal, slip or replace
- ▶ Integrated Oil Reservoir
- ▶ Built-in centrifugal clutch – allows for better horsepower transfer and the engine to idle without having the pump running
- ▶ Available in both vacuum/pressure or vacuum only model

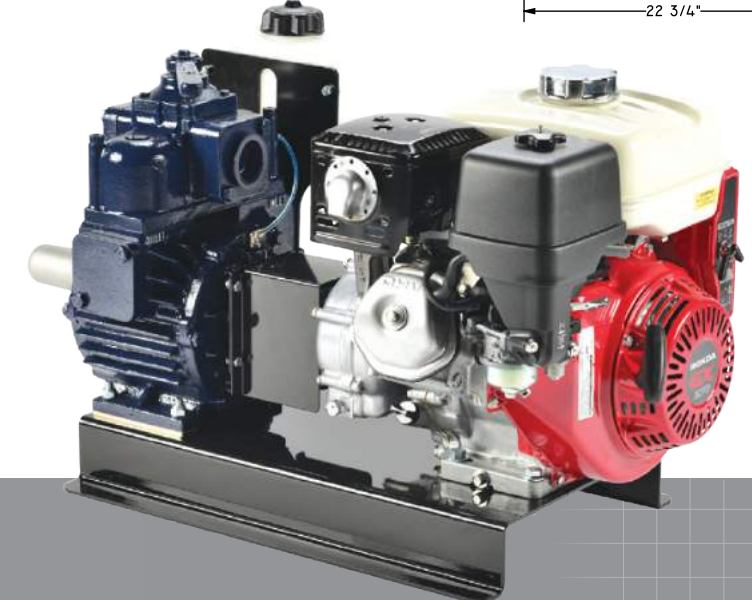
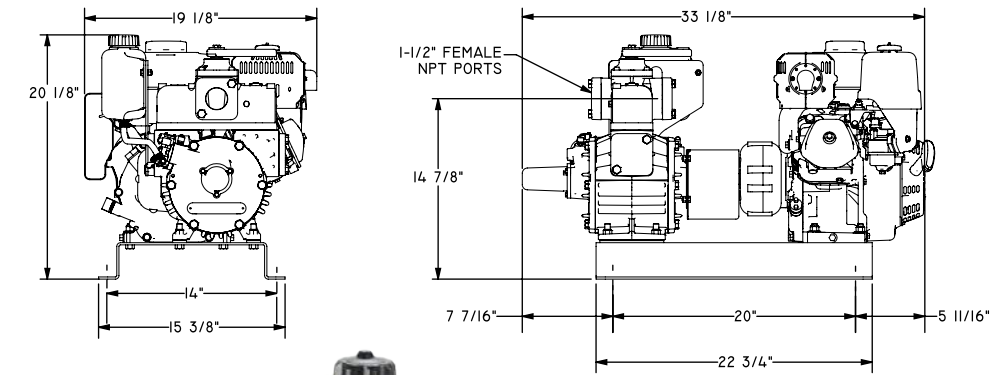

## Direct Drive Systems

# Pro Pack 1500

- ▶ Designed for tank sizes up to 1500 Gallons
- ▶ Made with a 13 Hp Honda Engine
- ▶ Available in 9 Hp Diesel Kubota Engine on request
- ▶ 165 CFM HXL4V Pump
- ▶ 20" Hg Continuous Duty
- ▶ 5-15 PSI Continuous Duty
- ▶ Electric Start
- ▶ Integrated Belt Guard – fully enclosing all moving parts for safety
- ▶ Available in both vacuum/pressure or vacuum only model

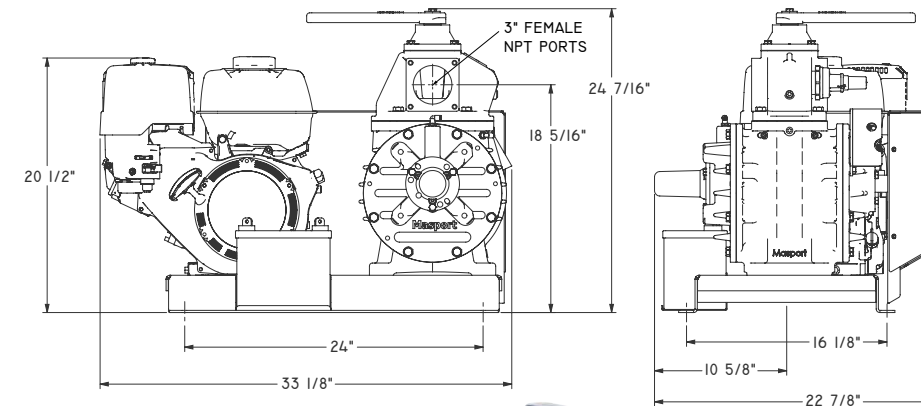
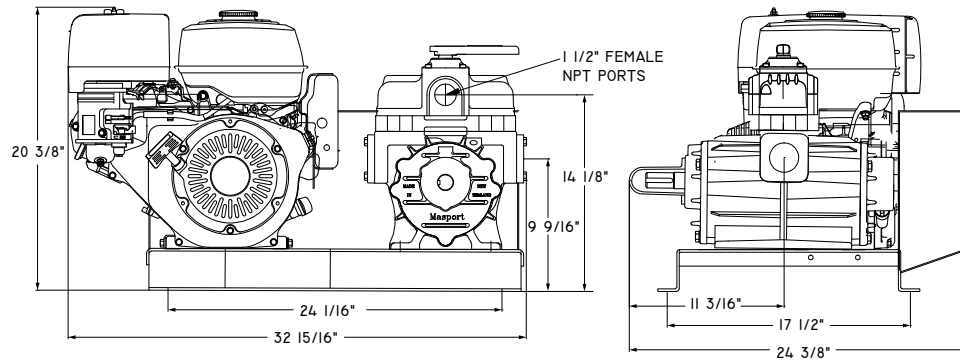

# Pro Pack 2500

- ▶ Designed for tank sizes up to 2500 Gallons
- ▶ Made with a 13 Hp Honda Engine
- ▶ Available in 19 Hp Diesel Kohler Engine on request
- ▶ 230 CFM HXL75V Pump
- ▶ 20" Hg Continuous Duty
- ▶ 15 PSI Continuous Duty
- ▶ Electric Start
- ▶ Integrated Belt Guard – fully enclosing all moving parts for safety



## Belt Drive Systems

# Pro Pack Plus

# System Upgrade

## Product Information

PRODUCT OVERVIEW									
System Number	12619	12621	12548	12626	12629	12628	12631	12630	12617
Pump Model	HXL2F	HXL2V	HXL2F	HXL2V	HXL3F	HXL3V	HXL4F	HXL4V	HX75V
Pump RPM	1,750	1,750	1,750	1,750	1,750	1,750	1,250	1,250	1,100
Pump Max CFM	75	75	75	75	112	112	165	165	230
Rec. Tank Size (Gal.)	100-750	100-750	100-750	100-750	750-1000	750-1000	1000-1500	1000-1500	1500-2000
Vacuum (Continuous)	20	20	20	20	20	20	20	20	20
Pressure (Continuous)	N/A	5	N/A	10	N/A	10	N/A	15	15
Oil Reservoir	Integral	Integral	Integral	Integral	Integral	Integral	Remote	Remote	Remote

ENGINE FEATURES									
Engine HP	5.5	5.5	9	9	9	9	13	13	13
Clutch	YES	YES	YES	YES	YES	YES	NO	NO	NO
Battery Included	NO	NO	NO	NO	NO	NO	YES	YES	YES

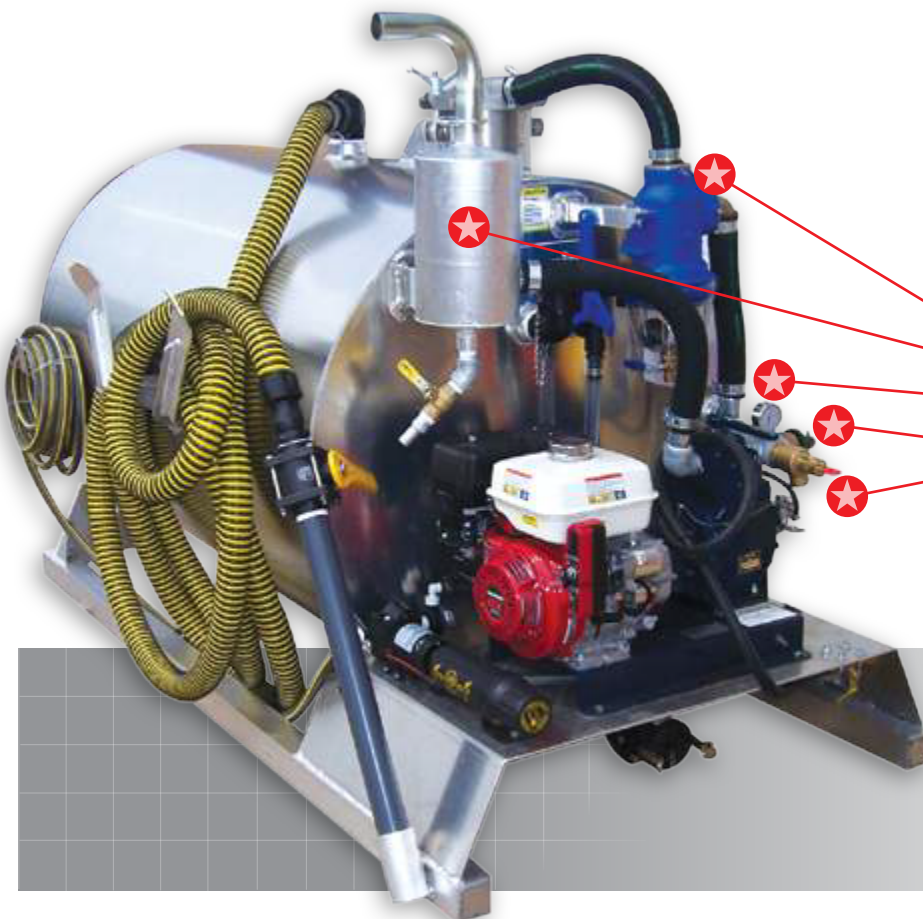

**Save money and simplify** your installation by upgrading your Pro Pack to the Pro Pack Plus. Masport's Pro Pack Plus includes all of the highlighted items that are essential for setting up and extending the life of your Pro Pack Engine Drive System.

- Secondary Moisture Trap
- Oil Separator
- Vacuum Pressure Gauge
- Vacuum Relief Valve
- Pressure Relief Valve

