

Masport have been manufacturing vacuum/pressure pumps and systems for over 100 years, so you can be sure of engineering excellence.

With a wide selection of pumps, systems and components specifically designed and engineered for the Liquid Waste Market, we can ensure that we have your pumping needs covered.

All products are factory tested before shipping and are backed up by a one year warranty against all manufacturing defects. With Masport on board you have an efficient and reliable pump and system backed by the best service and support that has made Masport the #1 choice for pumpers worldwide.

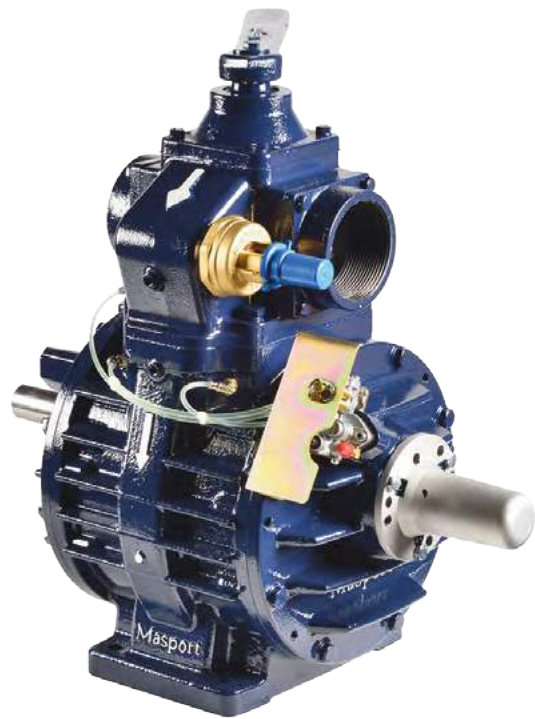



Features and benefits

- ▶ Achieve minimum 27" Hg (Intermittent)
- ▶ Available in both vacuum / pressure or vacuum only models
- ▶ Precise machining and assembly
- ▶ Heavy duty bearings
- ▶ Viton oil seals for longer service life
- ▶ Kevlar vanes are heat stabilized and machined with exacting tolerances for superior ruggedness and durability
- ▶ Superior pump life
- ▶ Mechanical oil pump with automatic oiling – no adjustment required
- ▶ Durable translucent high temperature oil lines – allows visible flow of oil to the pump
- ▶ Integral mounting bosses guarantee precise alignment for hydraulic drive or gearbox mount applications
- ▶ End Thrust Protection prevents rotor to-endcover contact
- ▶ 3" NPT bolt on valve flanges for ease of installation
- ▶ 1/4" NPT vane flush port
- ▶ Integral vacuum relief
- ▶ Double end shaft accommodates clockwise or counter-clockwise drive systems
- ▶ O-Ring Endcovers eliminates air or oil leakages
- ▶ Easy to service
- ▶ One year performance warranty



Features and benefits

- ▶ 20" Hg continuous duty operation
- ▶ Heavy duty pump stand
- ▶ High efficiency oil separator and scrubber
- ▶ Stainless steel inlet filter
- ▶ Vacuum/pressure relief valve and gauge
- ▶ Self-aligning gearbox and hydraulic drive options available
- ▶ Rexnord Omega Coupler on gearbox installations allows for greater life with automatic transmission
- ▶ Easily accessible maintenance points
- ▶ Oil, chemical and heat resistant hoses and float seat
- ▶ Separator supplied with 3" NPT fitting and exhaust deflector
- ▶ Available with plastic, steel or combination oil/flushing reservoir
- ▶ Available with or without oil separator
- ▶ Available with either a left or right handed scrubber
- ▶ One-year performance warranty

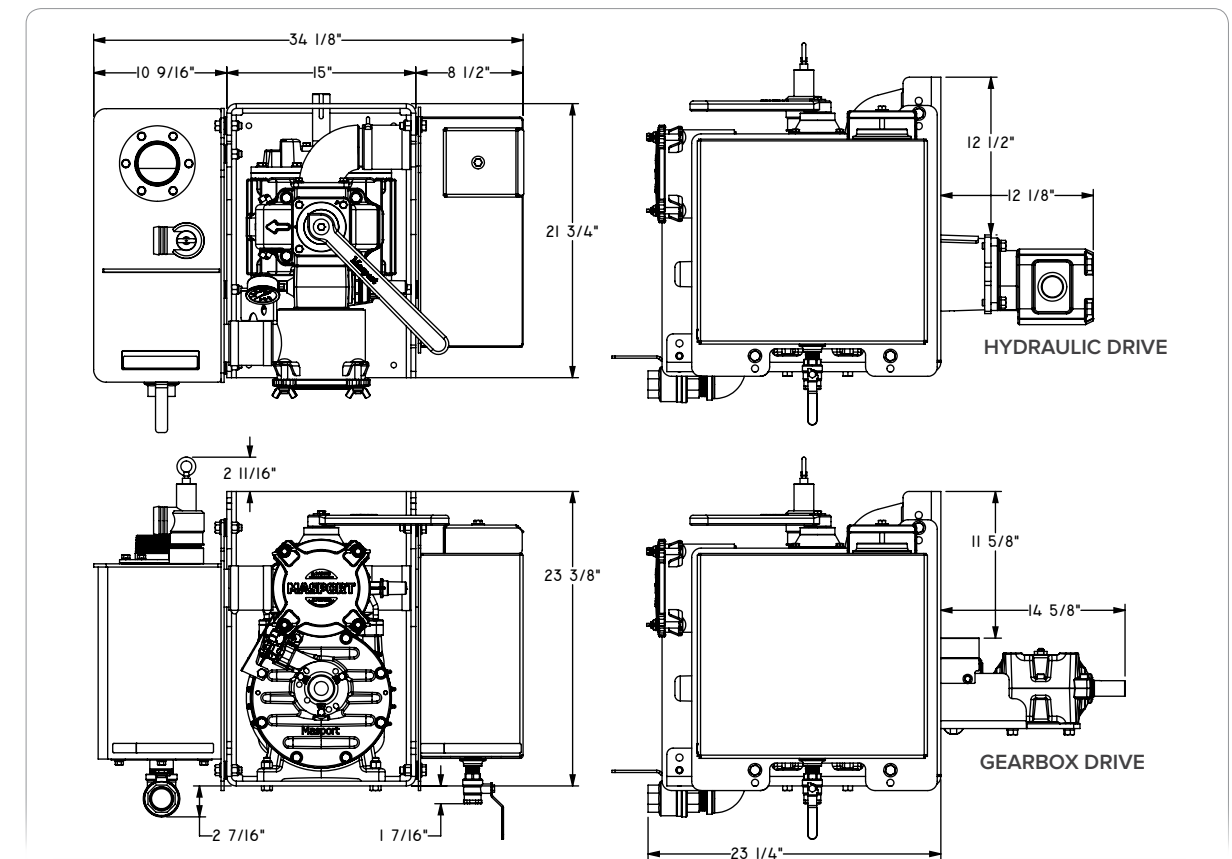
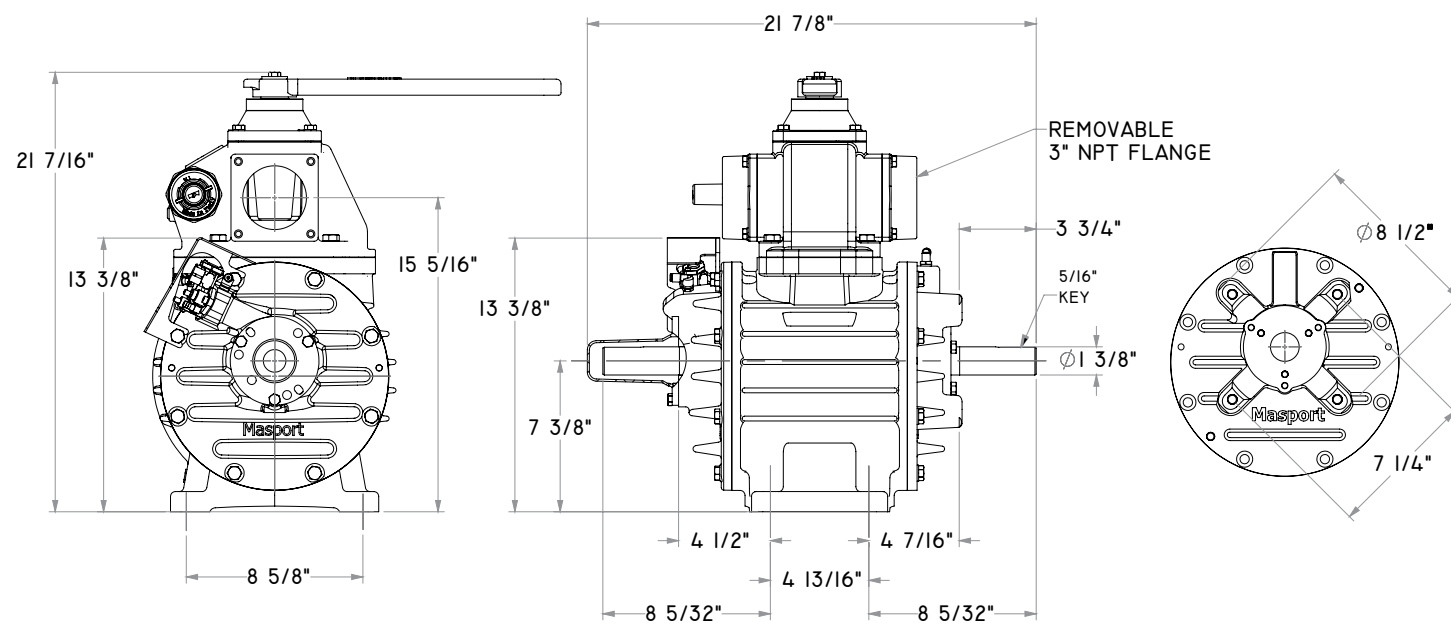

HXL75W Pump • 230 CFM DISPLACEMENT



Features and benefits

- ▶ Achieve minimum 27" Hg (Intermittent)
- ▶ Liquid stabilized design— provides reliable operation under extreme hot or cold weather conditions, and allows for higher continuous vacuum operations
- ▶ Precise machining and assembly
- ▶ Heavy duty bearings
- ▶ Viton oil seals for longer service life
- ▶ Kevlar vanes are heat stabilized and machined with exacting tolerances for superior ruggedness and durability
- ▶ Superior pump life
- ▶ Mechanical oil pump with automatic oiling – no adjustment required
- ▶ Durable translucent high temperature oil lines – allows visible flow of oil to the pump
- ▶ Integral mounting bosses guarantee precise alignment for hydraulic drive or gearbox mount applications
- ▶ End Thrust Protection prevents rotor to-endcover contact
- ▶ 3" NPT bolt on valve flanges for ease of installation
- ▶ 1/4" NPT vane flush port
- ▶ Integral vacuum relief
- ▶ Double end shaft accommodates clockwise or counter-clockwise drive systems
- ▶ O-Ring Endcovers eliminates air or oil leakages
- ▶ Easy to service
- ▶ One year performance warranty

HXL75W Plug & Play System



Features and benefits

- ▶ 25" Hg continuous duty operation
- ▶ Heavy duty pump stand
- ▶ High efficiency oil separator and scrubber
- ▶ Stainless steel inlet filter
- ▶ Vacuum/pressure relief valve and gauge
- ▶ Self-aligning gearbox and hydraulic drive options available
- ▶ Rexnord Omega Coupler on gearbox installations allows for greater life with automatic transmission
- ▶ Easily accessible maintenance points
- ▶ Oil, chemical and heat resistant hoses and float seat
- ▶ Separator supplied with 3" NPT fitting and exhaust deflector
- ▶ Available with plastic, steel or combination oil/flushing reservoir
- ▶ Available with or without oil separator
- ▶ Available with either a left or right handed scrubber
- ▶ One-year performance warranty

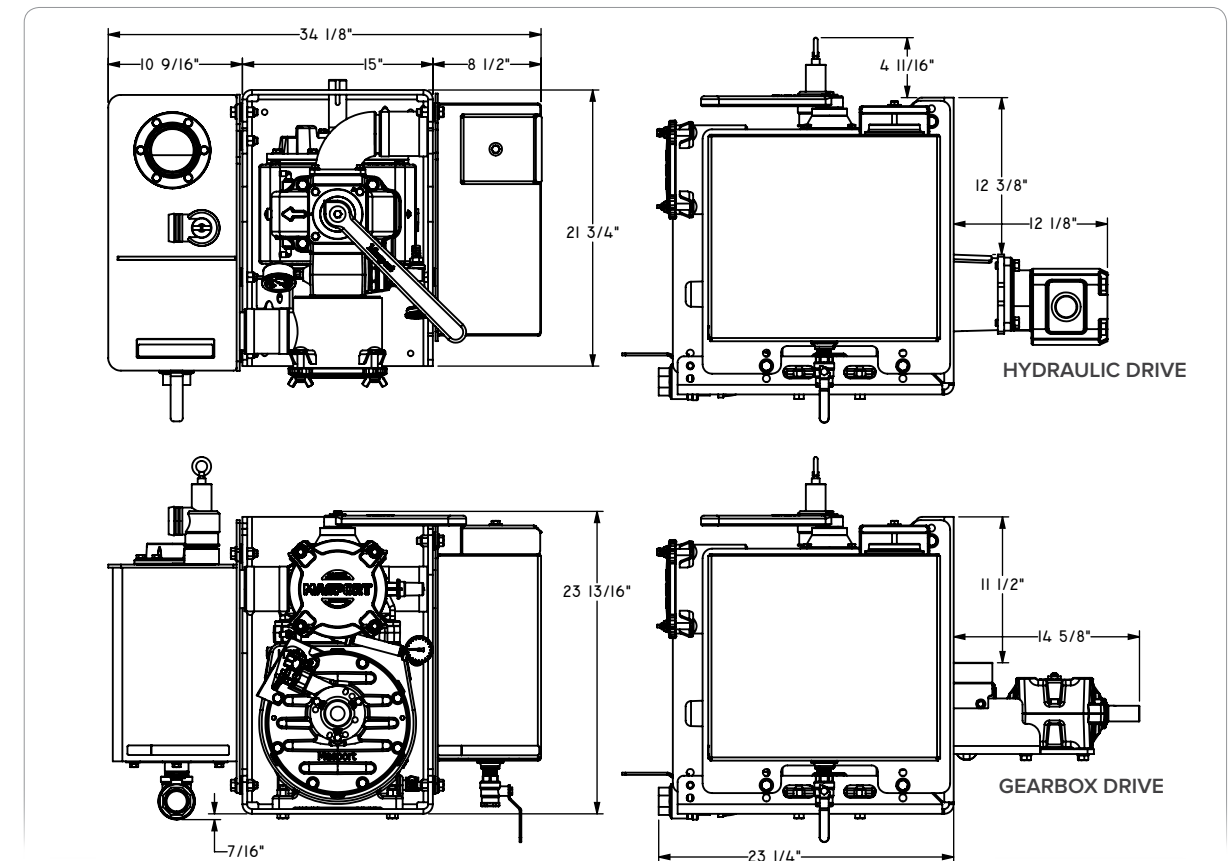
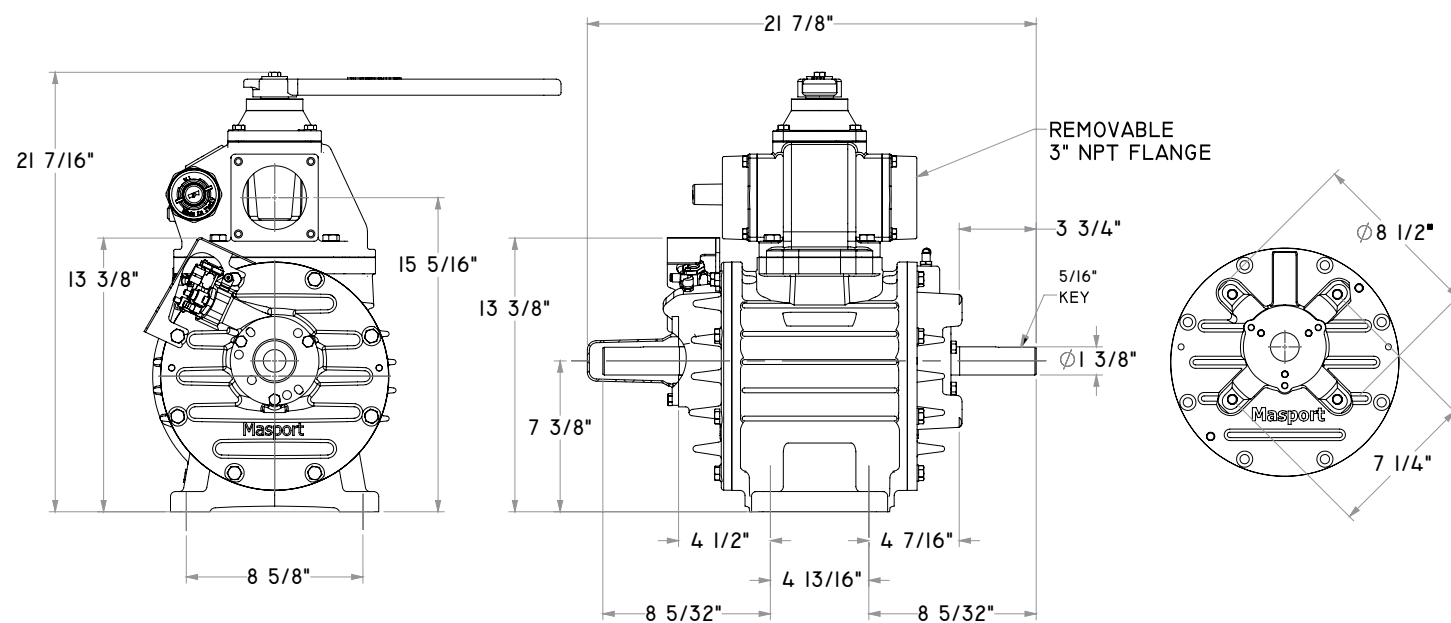

Titan Pump • 407CFM DISPLACEMENT

Features and benefits

- ▶ Achieve minimum 27" Hg (Intermittent)
- ▶ Fan cooled for higher continuous vacuum operations
- ▶ Precise machining and assembly
- ▶ Heavy duty bearings
- ▶ Viton oil seals for longer service life
- ▶ Kevlar vanes are heat stabilized and machined with exacting tolerances for superior ruggedness and durability
- ▶ Superior pump life
- ▶ Integrated inlet filter –washable stainless steel design for long filter life
- ▶ Mechanical oil pump with automatic oiling that delivers the right amount of oil at all working levels – no adjustment required
- ▶ Durable translucent high temperature oil lines – allows visible flow of oil to the pump
- ▶ Integral mounting bosses guarantee precise alignment for hydraulic drive or gearbox mount applications
- ▶ End Thrust Protection prevents rotor to-endcover contact
- ▶ 3" NPT bolt on valve flanges for ease of installation
- ▶ ¼" NPT vane flush port
- ▶ Integral vacuum relief
- ▶ Integral valve allows the pump to operate in vacuum and pressure mode and reduces plumbing and installation costs
- ▶ O-Ring Endcovers eliminates air or oil leakages
- ▶ Easy to service
- ▶ One year performance warranty



Titan Plug & Play System

Features and benefits

- ▶ 22" Hg continuous duty operation
- ▶ Heavy duty pump stand
- ▶ Compact high efficiency oil separator and scrubber
- ▶ Stainless steel integral inlet filter
- ▶ Vacuum/pressure relief valve and gauge
- ▶ Pressure Relief Valve Vent Recovery System eliminates clean-up with to oil exhausted to atmosphere
- ▶ Self-aligning gearbox and hydraulic drive options available
- ▶ Rexnord Omega Coupler on gearbox installations allows for greater life with automatic transmission
- ▶ Easily accessible maintenance points
- ▶ Oil, chemical and heat resistant hoses and float seat
- ▶ Separator supplied with 3" NPT fitting and exhaust deflector
- ▶ Available with plastic, steel or combination oil/flushing reservoir
- ▶ Available with or without oil separator
- ▶ Available with either a left or right handed scrubber
- ▶ One-year performance warranty

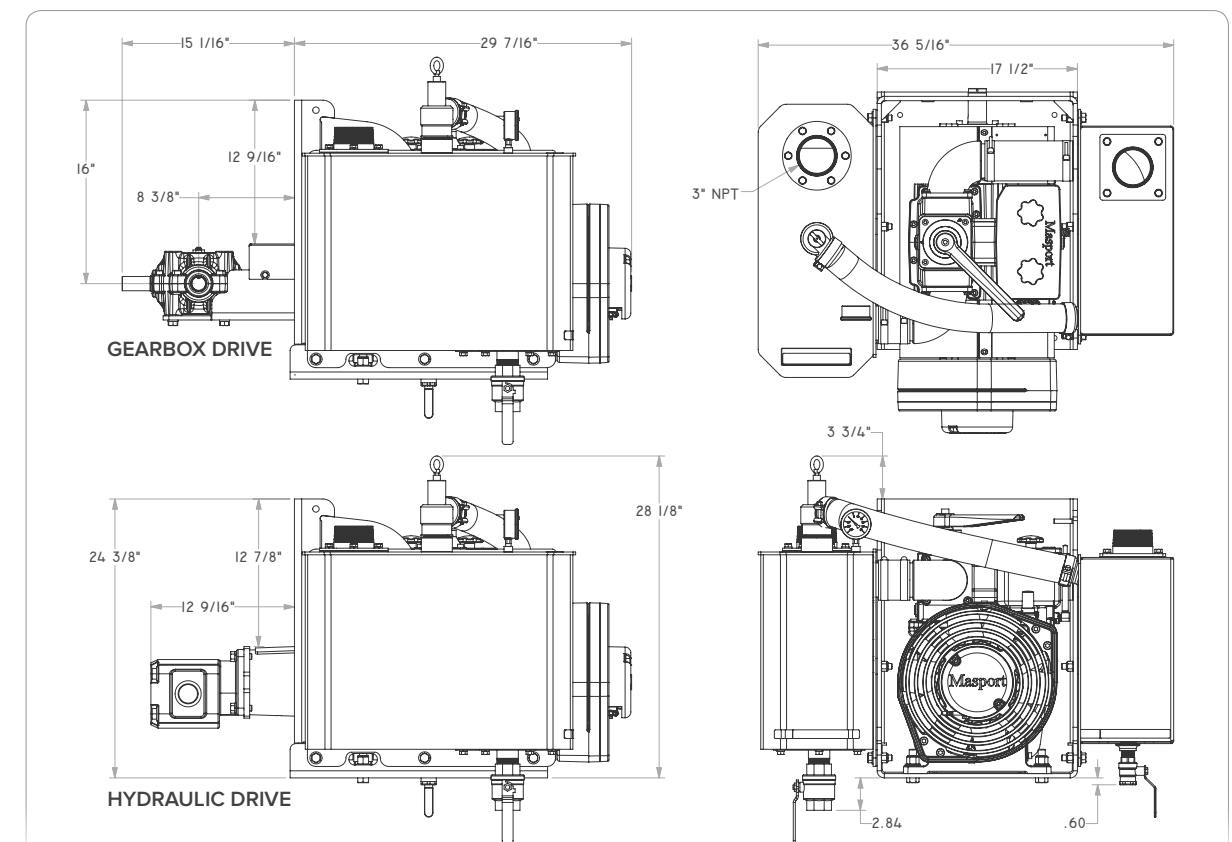
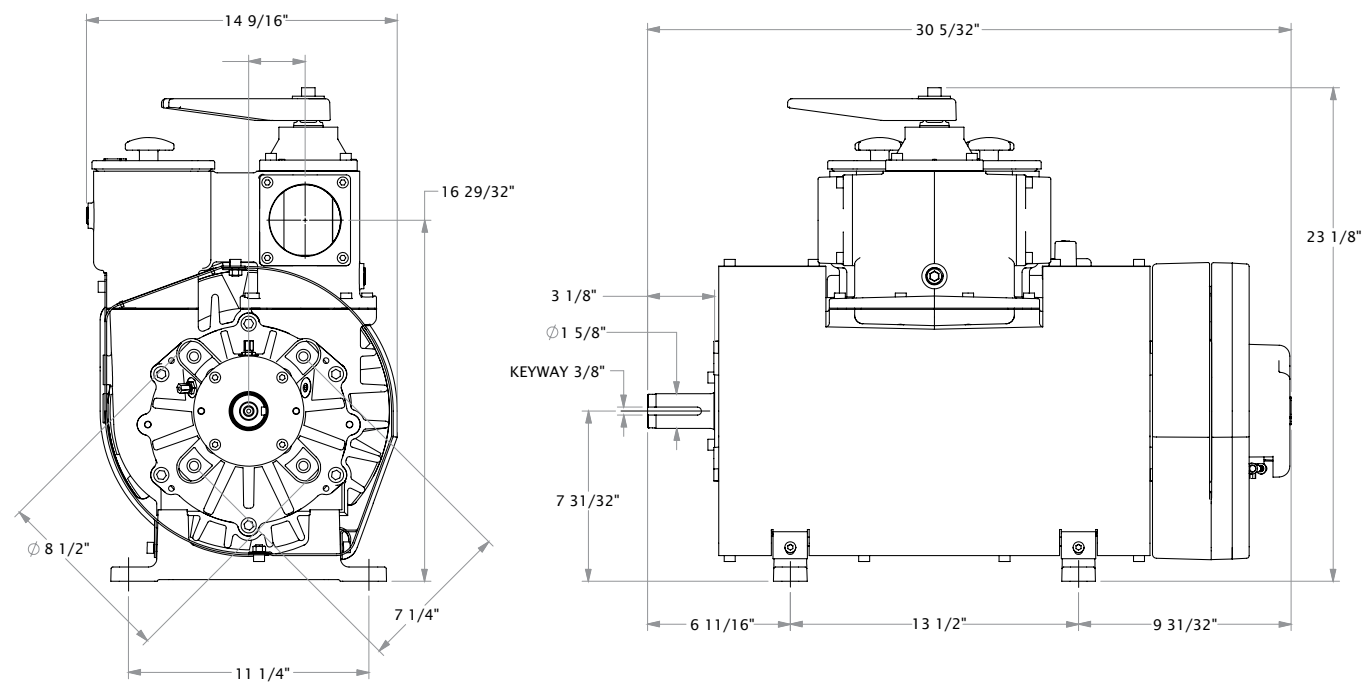

Hydra Pump • 407CFM DISPLACEMENT



Features and benefits

- ▶ **Achieve minimum 27" Hg** (Intermittent)
- ▶ **Liquid stabilized design**— provides reliable operation under extreme hot or cold weather conditions, and allows for higher continuous vacuum operations
- ▶ **Precise machining and assembly**
- ▶ **Heavy duty bearings**
- ▶ **Viton oil seals** for longer service life
- ▶ **Kevlar vanes** are heat stabilized and machined with exacting tolerances for superior ruggedness and durability
- ▶ **Vane wear inspection ports**
- ▶ **Superior pump life**
- ▶ **Integrated inlet filter**—washable stainless steel design for long filter life
- ▶ **Mechanical oil pump** with automatic oiling that delivers the right amount of oil at all working levels – no adjustment required
- ▶ **Durable translucent** high temperature oil lines – allows visible flow of oil to the pump
- ▶ **Integral mounting bosses** guarantee precise alignment for hydraulic drive or gearbox mount applications
- ▶ **End Thrust Protection** prevents rotor to-endcover contact
- ▶ **3" NPT bolt on valve flanges** for ease of installation
- ▶ **1/4" NPT vane flush port**
- ▶ **Integral vacuum relief**
- ▶ **Integral valve** allows the pump to operate in vacuum and pressure mode and reduces plumbing and installation costs
- ▶ **O-Ring Endcovers** eliminates air or oil leakages
- ▶ **Easy to service**
- ▶ **One year performance warranty**

Hydra Plug & Play System



Features and benefits

- ▶ **25" Hg continuous duty operation**
- ▶ **Heavy duty pump stand**
- ▶ **Compact high efficiency oil separator and scrubber**
- ▶ **Stainless steel integral inlet filter**
- ▶ **Vacuum/pressure relief valve and gauge**
- ▶ **Pressure Relief Valve Vent Recovery System** eliminates clean-up with oil exhausted to atmosphere
- ▶ **Self-aligning gearbox and hydraulic drive options available**
- ▶ **Rexnord Omega Coupler** on gearbox installations allows for greater life with automatic transmission
- ▶ **Easily accessible maintenance points**
- ▶ **Oil, chemical and heat resistant hoses and float seat**
- ▶ **Separator supplied with 3" NPT fitting and exhaust deflector**
- ▶ **Available with plastic, steel or combination oil/flushing reservoir**
- ▶ **Available with or without oil separator**
- ▶ **Available with either a left or right handed scrubber**
- ▶ **One-year performance warranty**

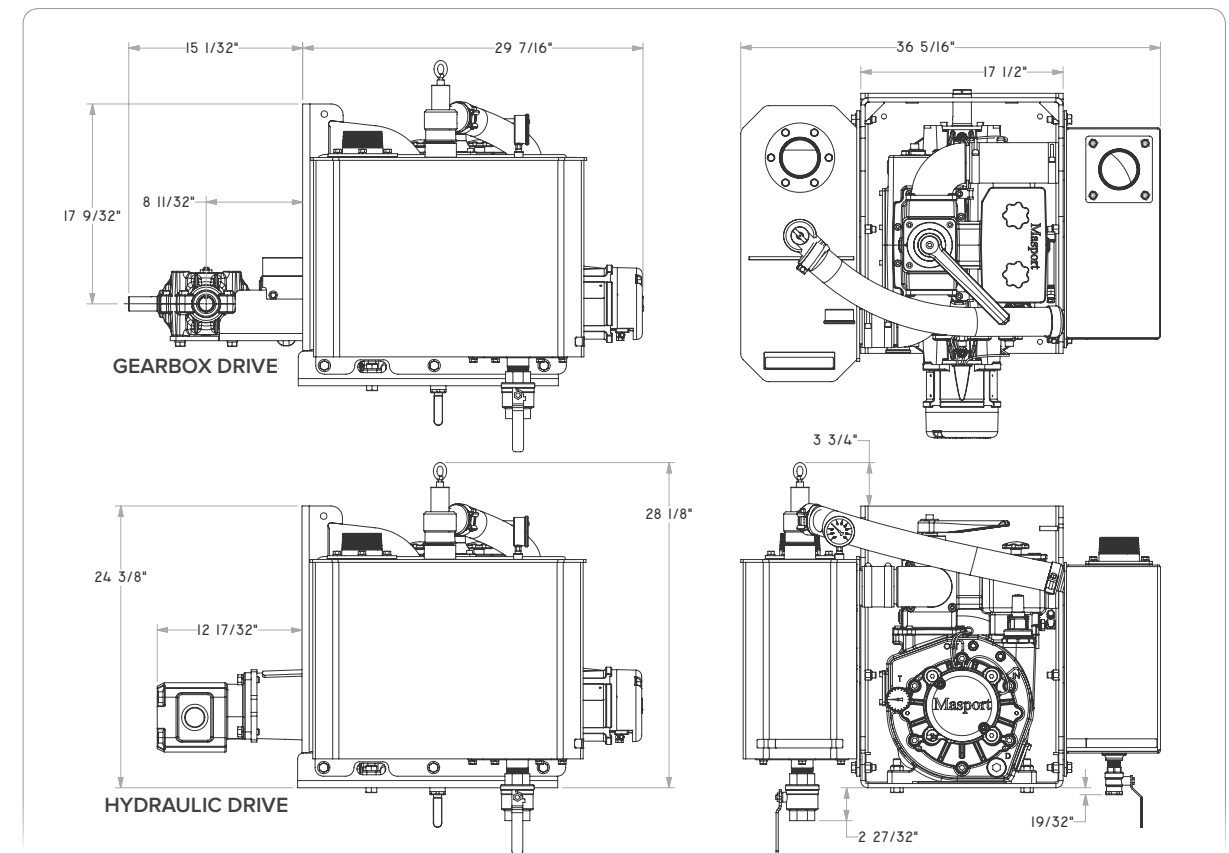
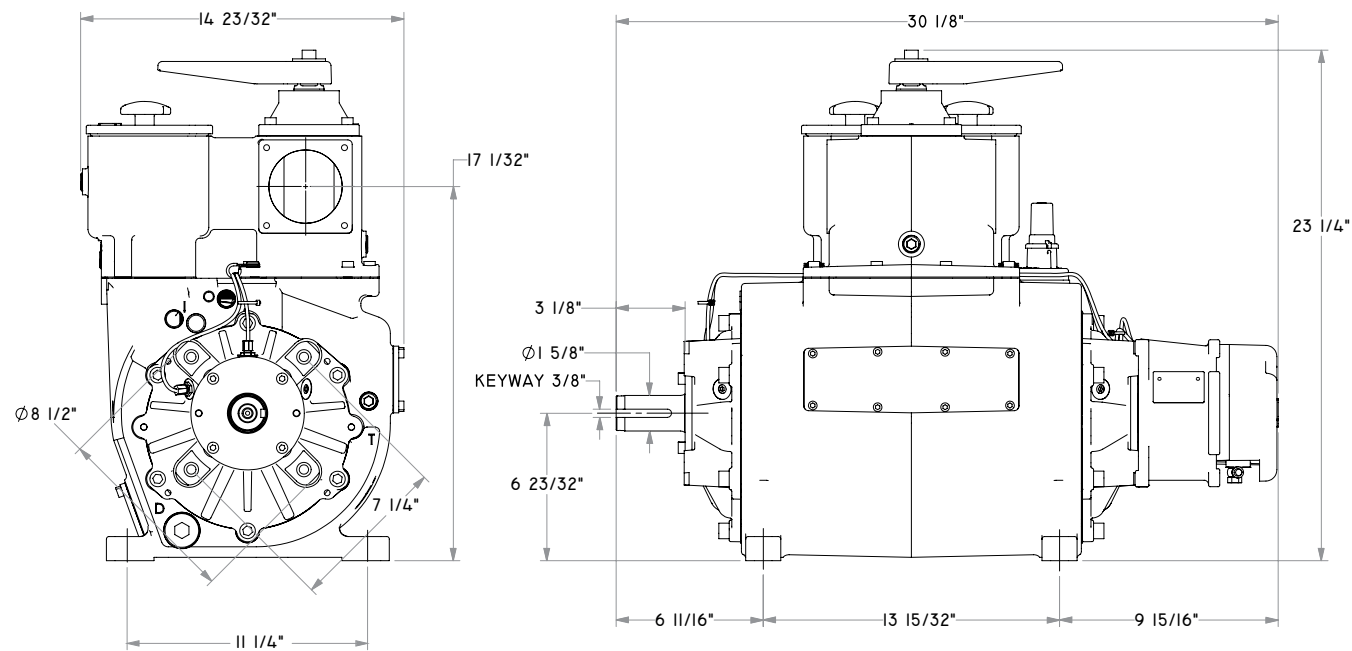

Masport Tank Components & Accessories

1 Primary Trap

- ▶ Available in a range of sizes to suit airflow from 20 – 400 CFM
- ▶ Port sizes in 1½" and 3"
- ▶ Steel Collar



9 Sight Glasses

- ▶ 5" Tempered Glass Design
- ▶ Steel collar



6 Relief Valves

- ▶ Vacuum Relief Valve 1½"
- ▶ Pressure Relief Valve 1½" and 2"



3 Oil Separator

- ▶ Available in a range of sizes to suit airflow from 20 – 400 CFM
- ▶ Port sizes in 1½", 2½" and 3"
- ▶ Steel or aluminium construction
- ▶ Painted or unpainted finish



2 Scrubber

- ▶ Available in a range of sizes to suit airflow from 20 – 400 CFM
- ▶ Port sizes in 1½", 2½" and 3"
- ▶ Horizontal and vertical designs
- ▶ Painted or unpainted finish



4 Pre-Filter

- ▶ Available in a range of sizes to suit airflow from 20 – 400 CFM
- ▶ Port sizes in 1½" and 3"
- ▶ Painted or unpainted finish



5 Vacuum/Pressure Gauges

- ▶ Available as either vacuum only or combined vacuum and pressure

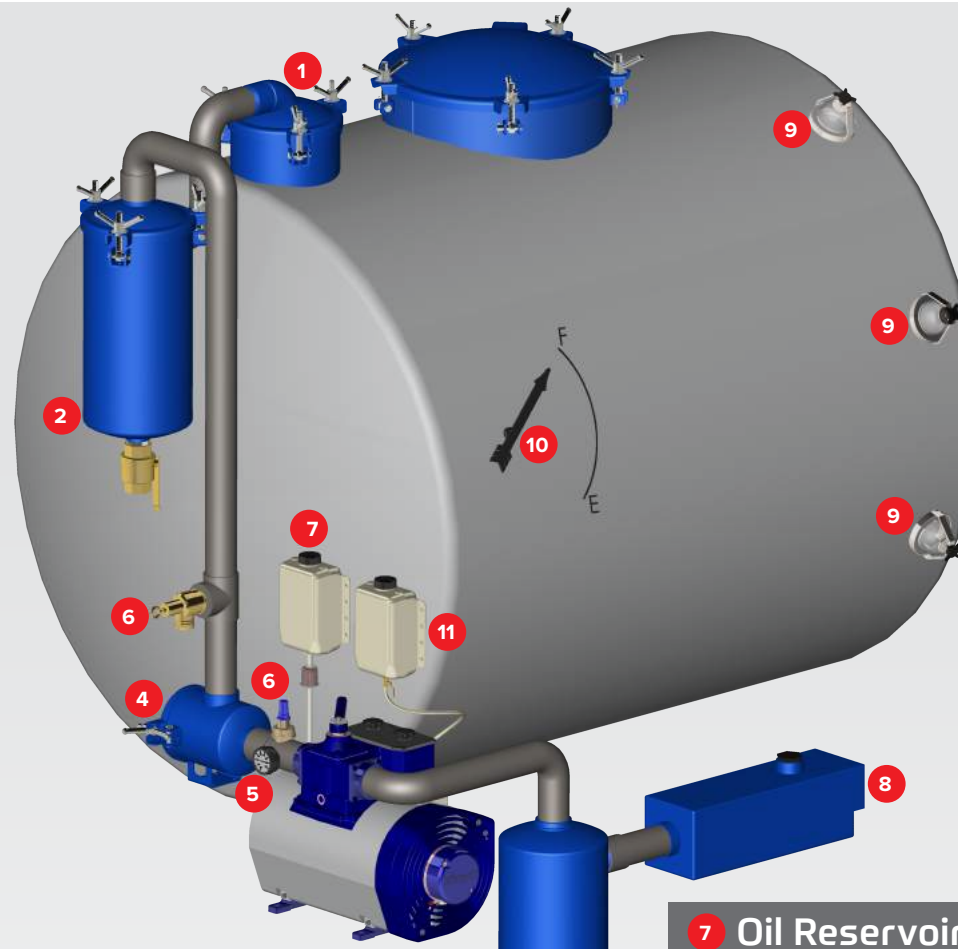

7 Oil Reservoir

- ▶ Includes all components to properly oil the pump
- ▶ Select from either plastic or steel reservoir tanks
- ▶ Specially formulated Masport Oil available



8 Pumper Scent

- ▶ Effectively remove foul odors when pumping
- ▶ Port sizes in 1½", 2", 3" and 4"



10 Tank Level Indicator

- ▶ External indicator arrow
- ▶ Steel collar



11 Flushing Kit

- ▶ Includes all components to properly flush the pump
- ▶ Select from either plastic or steel reservoir tanks
- ▶ Specially formulated Masport Flushing Fluid available



Product Information

Pumps

PRODUCT OVERVIEW								
Pump Number	968685	968675	968670	968980	969910	969900	969960	969950
Pump Model	HXL75F	HXL75V	HXL75WV	HXL400WV	Titan CW	Titan CCW	Hydra CW	Hydra CCW
Pump RPM	1000-1250	1000-1250	1000-1250	1000-1250	1000-1400	1000-1400	1000-1400	1000-1400
Pump Max CFM	230	230	230	400	407	407	407	407
Rec. Tank Size (Gal.)	1500-2500	1500-2500	1500-2500	2500-6000	2500-6000	2500-6000	2500-6000	2500-6000
Vacuum (Continuous)	20	20	25	25	22	22	25	25
Pressure (Continuous)	N/A	20	20	20	20	20	20	20

Plug & Play Systems

PRODUCT OVERVIEW						
System Number	12762	12763	12765	12768	12760	12761
Pump Model	HXL75V	HXL75V	HXL75V	HXL75V	HXL75WV	HXL75WV
Pump Max CFM	230	230	230	230	230	230
Rec. Tank Size (Gal.)	1500-2500	1500-2500	1500-2500	1500-2500	1500-2500	1500-2500
Vacuum (Continuous)	20	20	20	20	25	25
Pressure (Continuous)	20	20	20	20	20	20

SYSTEM FEATURES						
Configuration	Right Hand Scrubber	Left Hand Scrubber	Right Hand Scrubber	Left Hand Scrubber	Right Hand Scrubber	Left Hand Scrubber
Oil Separator Included	NO	NO	YES	YES	NO	NO

PRODUCT OVERVIEW						
System Number	12764	12767	12920	12914	12919	12915
Pump Model	HXL75WV	HXL75WV	Titan	Titan	Hydra	Hydra
Pump Max CFM	230	230	407	407	407	377
Rec. Tank Size (Gal.)	1500-2500	1500-2500	2500-6000	2500-6000	2500-6000	2500-6000
Vacuum (Continuous)	25	25	22	22	25	25
Pressure (Continuous)	20	20	20	20	20	20

SYSTEM FEATURES						
Configuration	Right Hand Scrubber	Left Hand Scrubber	Right Hand Scrubber	Left Hand Scrubber	Right Hand Scrubber	Left Hand Scrubber
Oil Separator Included	YES	YES	YES	YES	YES	YES

Masport Plug & Play System Ordering

The Masport standardized part number format is designed to simplify the ordering process for our customers.

The format takes the following form:

XXXXX A B

The first five numbers (denoted by the X) represents the bare system number (i.e. no drive system or oil reservoir kit installed/included).

The first letter (denoted by A) represent the type of oil reservoir kit included; i.e. Plastic (**P**), Steel (**S**) or Dual (**D**).

The second letter (denoted by B) represent the type of drive assembly mounted onto the pump/system i.e. Clockwise Gearbox Drive (**CW**) or Counter-clockwise Gearbox Drive (**CCW**) or hydraulic drive (**H**) and so on.

For example:

An order for an Titan Plug & Play with a Plastic Oil Reservoir Kit and a Counter-clockwise Gearbox Drive would be:

12914PCCW

Referring to the Product Information tables on the facing page and the Part Code Identifier table on this page, the example **12914PCCW** is made up of the following:

12914 Bare system number (from the Plug & Play Systems Table)

P Plastic Oil Reservoir Kit

CCW Counter-clockwise Gearbox Drive Assembly with Rexnord Coupler Installed on Pump/System.

Please note:

Customers do not have to order systems that contain all the elements. A bare system can be ordered as per the following examples:







12914 (Titan Plug & Play System),

or

12914CCW (a system with only a drive assembly),

or

12914S (a system with only a Steel Oil Reservoir Kit).

PART CODE IDENTIFIER	IMAGE	DESCRIPTION
P		Plastic Oil Reservoir Kit comes supplied with the Pump/System – to be installed by the purchaser
S		Steel Oil Reservoir Kit comes supplied with the Pump/System – to be installed by the purchaser
D		Dual Tank Oil Reservoir / Flushing Kit comes supplied with the Pump/System – to be installed by the purchaser
CW		Clockwise Gearbox Drive Assembly with Rexnord Coupler comes supplied and already installed on the Pump/System
CCW		Counter-Clockwise Gearbox Drive Assembly with Rexnord Coupler comes supplied and already installed on the Pump/System
H		Hydraulic Drive Assembly comes supplied and already installed on the Pump/System



Liquid Waste Pump Systems



BUILT FOR THE HARD WORKING PUMPER

Masport Incorporated
6801 Cornhusker Highway, Lincoln, NE 68507, USA

Phone: 800 228 4510
Email: cs@masportpump.com
www.masportpump.com