

## HXL-Series II , Vacuum / Pressure Pumps

### HXL15WV

#### ◆ Mechanical Oil Pump

- Automatic Oiling.
- No Adjustment Required.
- Delivers Right Amount of Oil at All Working Levels.

#### ◆ Liquid Cooled Design

- Prevents Winter Freeze-ups.
- Allows Pump to Operate @ 25”Hg Continuously.
- Reliable Operation Under Extreme Hot or Cold Weather Conditions.

#### ◆ End Thrust Protection

- Prevents Rotor-to-Endcover Contact Created by Direct P.T.O. Drive or Misaligned Belt Driven Systems.

#### ◆ Integral Valve

- Allows Pump to Operate in Vacuum and Pressure Mode.
- Reduces Plumbing and Installation Costs.

#### ◆ Double End Shaft

- Accommodates Clockwise or Counter-Clockwise Drive Systems.



#### ◆ Masport Quality & Performance

- Achieve Minimum 27” Hg (Intermittent).
- Precise Machining and Assembly.
- Heavy Duty Bearings.
- Viton Oil Seals for Longer Service Life.
- Kevlar Vanes are Heat Stabilized and Machined with Exacting Tolerances for Superior Ruggedness and Durability.
- Easy to Service.
- Superior Pump Life.

#### ◆ Performance Warranty

- One Year Warranty.

# PERFORMANCE DATA

## Performance Data – Vacuum

Pump R.P.M.	Displacement C.F.M.	S.C.F.M. and A.C.F.M. @ VACUUM											Maximum Vacuum – “Hg	
			5	10	15	18	20	22	24	25	26	27	Continuous	Intermittent
1100	303	SCFM	211	165	120	90	71	54	31	23	15	5.2	25	27
		ACFM	253	248	239	225	213	201	153	136	113	52		
1275	350	SCFM	246	175	139	104	83	62	38	26	16	6	25	27
		ACFM	295	263	278	261	248	233	192	158	118	60		

## Performance Data – Pressure

Pump R.P.M.	Displacement C.F.M.	S.C.F.M. @ P.S.I.G.							Maximum Pressure – P.S.I.G.	
		5	10	15	18	20	25	30	Continuous	Intermittent
1100	303	254	242	231	217	204	192	180	20	30
1275	350	293	279	266	251	235	222	207	20	30

## Horsepower Required @ P.S.I.G.

Pump R.P.M.	P.S.I.G.					
	5	10	15	20	25	30
1000	12.2	15.8	20.2	24.1	28	31.5
1100	13.5	17.4	22.2	26.5	30.8	34.7
1250	15.6	20.1	25.7	30.7	35.7	40.2

## Horsepower Required @ “Hg

Pump R.P.M.	Vacuum “Hg				
	5	10	15	20	27
1000	9.1	10.8	11.4	12.5	14
1100	10	11.8	12.5	13.7	15.4
1250	11.6	13.7	14.5	15.9	17.8

# DIMENSIONAL DATA

## HXL15WV Pump

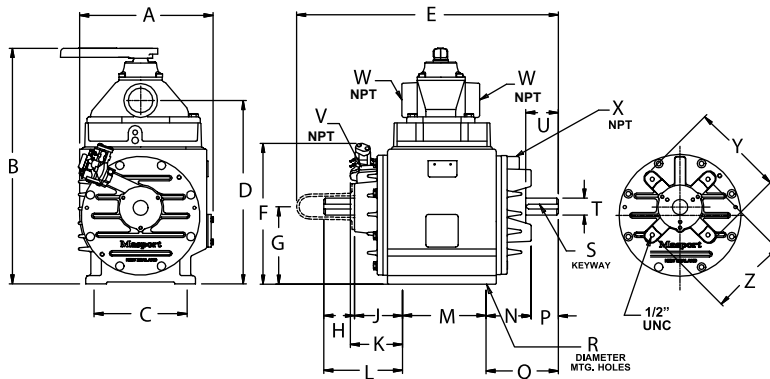

## HXL15WF Pump

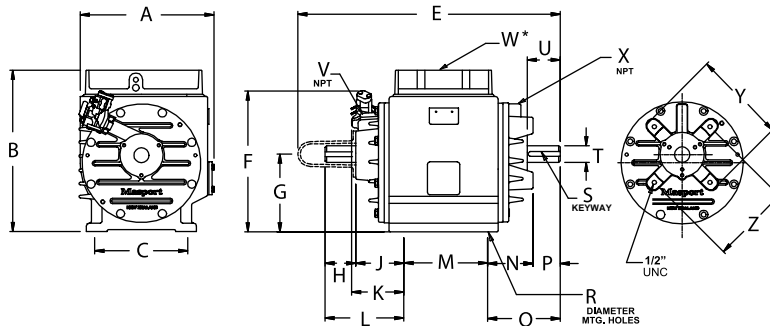

	HXL15WV	HXL15WF
A	13	13
B	24	16 1/16
C	8 11/16	8 11/16
D	19 5/16	—
E	25 29/32	25 29/32
F	12 5/8	12 5/8
G	7 7/16	7 7/16
H	3 25/32	3 25/32
J	4 1/4	4 1/4
K	5 1/32	5 1/32
L	8 1/32	8 1/32
M	9 7/16	9 7/16
N	4 13/32	4 13/32
P	3 5/8	3 5/8
Q	8 1/32	8 1/32
R	9/16	9/16
S	5/16 x 5/16 x 2	5/16 x 5/16 x 2
T	1 3/8	1 3/8
U	4 1/8	4 1/8
V	1/8	1/8
W	3	2 1/2
X	1/4	1/4
Y	8 15/32	8 15/32
Z	7 1/4	7 1/4

ALL DIMENSIONS IN INCHES.

For additional information on these quality Masport Vacuum / Pressure Pumps contact:



## MASPORT INCORPORATED

6140 McCormick Drive

Lincoln, Nebraska 68507

Ph: 402-466-8428 Fax: 402-466-8355

Web: [www.masportpump.com](http://www.masportpump.com)

CALL TOLL FREE 800-228-4510



# PARTS LIST HXL15WV II

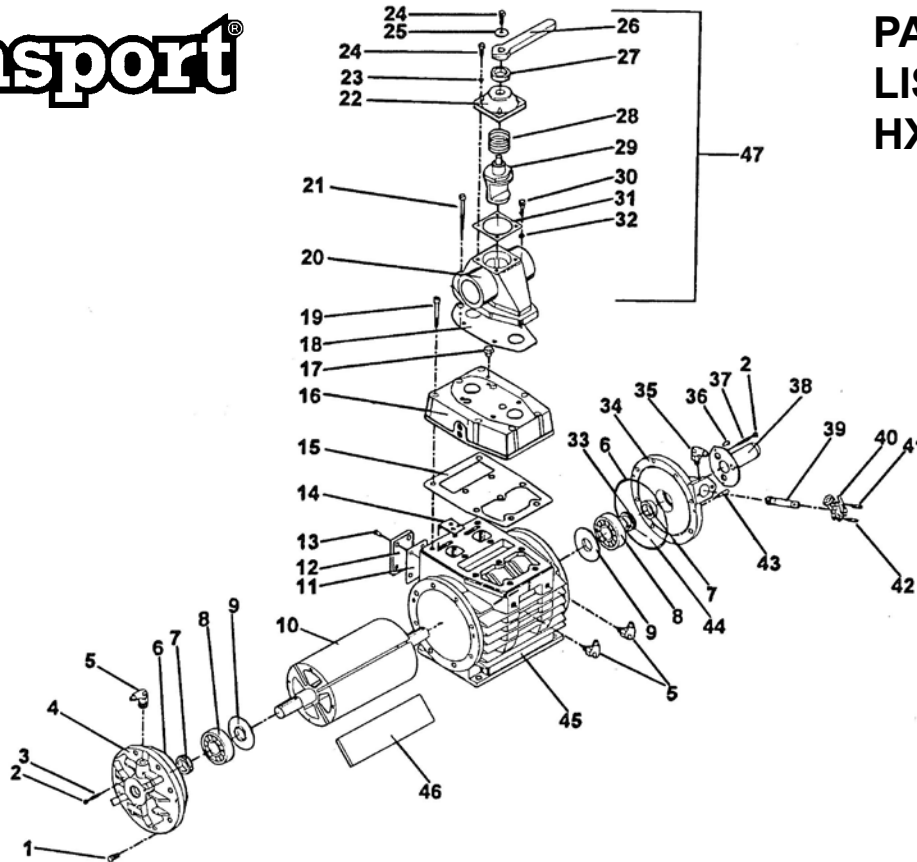

## HXL15WV SERIES II LIQUID COOLED PRESSURE / VACUUM PUMP PARTS LIST (968840)

Ref	Description	Part No.	Qty.	Ref	Description	Part No.	Qty.
1	Bolt	501569	16	28	Spring	568038	1
2	Nut	504278	6	29	Spool	968804	1
3	Set Screw	504276	3	30	Bolt	501666	4
4	Endcover	968843	1	31	Gasket	568044	1
5	Swivel Elbow	568086	3	32	Washer	500203	5
6	O-Ring	501677	2	33	Gear	568158	1
7	Oil Seal	501015	2	34	Endcover	968854	1
8	Bearing	503098	2	35	Swivel Elbow	568085	1
9	Bearing Spacer	968611	2	36	Bolt	501571	3
10	Rotor Assembly (Incl. 8, 9)	968848	1	37	Set Screw	504277	3
11	Gasket	568232	1	38	Shaft Guard	568622	1
12	Side Plate	968231	1	39	Drive Shaft Assembly	968045	1
13	Bolt	501597	4	40	Oil Pump	568437	1
14	Flap Assembly	968026	2	41	Cap Screw	504262	1
15	Gasket	568805	1	42	Cap Screw	504261	1
16	Manifold	968802	1	43	Dowel Pin	503258	4
17	Plug	27300	1	44	Set Screw	504264	1
18	Gasket	568806	1	45	Cylinder	968801	1
19	Cap Screw	501965	10	46	Vane Pack (4)	968218	1
20	Valve Body	968012	1	47	Integral Valve Assembly (Incl. 20,21,22,23,24,25, 26,27,28,29,30,31,32)	968006	1
21	Bolt	502061	1	48	Endcover Shim Gasket **		
22	Cap	968035	1		.002" Thickness	542011	***
23	Washer	501610	4		.003" Thickness	542012	***
24	Bolt	501617	5	49	Oil Line (ft.) **	600293	***
25	Washer	501550	1				
26	Handle	968037	1				
27	Oil Seal	501674	1				

\*\* NOT SHOWN \*\*\* QUANTITY VARIES