

Maintenance manual
Water cooled
vacuum pumps

Introduction

Please follow carefully the instructions of the manual for a correct installation, use and maintenance of your vacuum pump.

Important issues

Starting

Start off the pump slowly. Forced engagement may cause damage to the transmission.

Stopping

Disengage the pump transmission before stopping the drive. Do not stop the engine while the pump is operating.

Operating

- Do not block or alter the relief valves adjustment, in order to avoid damage or explosion.
- Do not splash the pump with water or other liquid while the pump is running.
- Keep the rotation speed within the given limits.

In case of any obstruction along the suction line stop the pump and remove the cause.

Do not adjust the flow by means of gate valves or relief valves which are not suitable for such purpose. The flow and the vacuum rate can be adjusted changing the speed of the pump.

The pump must be installed according to local safety requirements. In the countries of the common market according to standard n° 89/392 CEE.

Weekly maintenance

Suction filter

The pump must be stopped while cleaning the suction filter. The filter can be cleaned using detergent liquid, diesel fuel and a high pressure jet of air.

Safety relief valve

Both pressure or vacuum relief valves must be cleaned and checked periodically

Non-return valve

In case of vibrations the check valve must be replaced.

We suggest that expert personnel must check the pump once a year. Wear parts must be replaced within three years.

Contents

1	Dimensions and performances	4.2	Performance control
2	Installation	4.3	Temperature of the cooling liquid
2.1	Initial check	4.4	Intake of liquids
2.2	Protection of the inlet port	4.5	Checking of the wear of the vanes
2.3	Protection against intake of liquids	4.6	Replacement of the vanes
2.4	Non-return check valve	4.7	Cleaning of filter
2.5	4 way valve	4.8	Preliminary maintenance
2.6	Exhauster/Oil separator	4.9	Trouble shooting
2.7	Cooling of the pump	5	Spare parts list
2.8	Pressure relief valve	5.1	How to order the spare parts
2.9	Vacuum relief valve	5.2	Spare parts list of P150R
3	Running of the pump	5.3	Spare parts list of P200R
3.1-3.6	Check of the start-off and running of the pump	5.4	Spare parts list of P250R
4	Maintenance of the vacuum pump		
4.1	Lubrication		

1 Dimensions and performances

Vacuum pump/compressor. Series PR.

Lubricated, sliding vanes pump.

Application

- Sludge and slurry suction vehicles . Dusty materials with suitable suction filter.
- Vacuum plants.
- Pneumatic transport installations.

Drive

- By vehicle engine with mechanical transmission.
- With auxiliary engine, electric motor, etc.
- Hydrostatic drive.

NOTE The pumps are delivered for right or left rotation upon request.

Cooling and lubrication

Cooling is obtained by forced circulation with external pump.

Automatic oil lubrication of the moving parts with a piston pump driven by the rotor. High capacity oil tank with level sightglass.

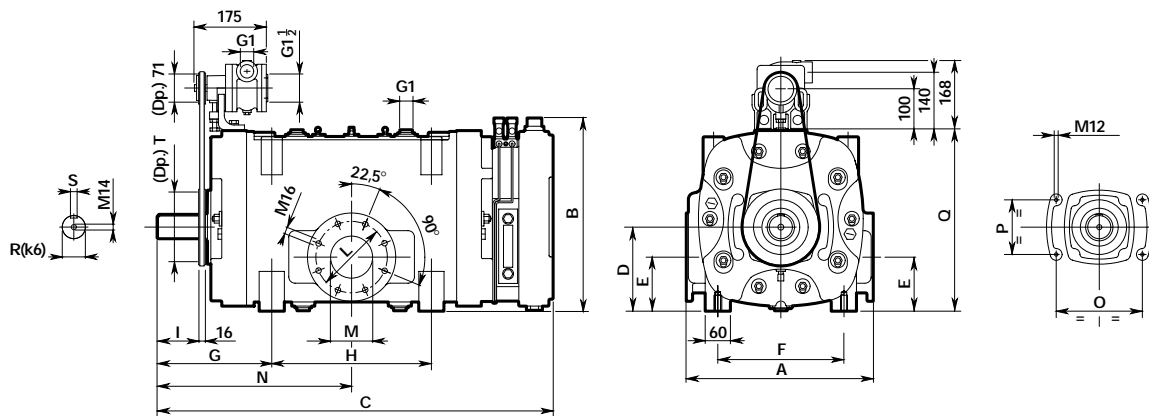

Dimensions mm

Mod.	A	B	C	D	E	F	G	H	I	L	M	N	O	P	Q	R	S	T
PR150	400	435	866	187	120	280	256	320	80	150	90	416	185	110	402	45	14	150
PR200	445	460	943	200	128	300	273	380	99	170	100	463	205	130	430	55	16	180
PR250	445	460	1123	200	144	300	283	540	99	200	130	553	205	130	430	55	16	180

Performances

Mod.	PR150	PR200	PR250	
Suggested speed	min ⁻¹	1200	1200	1100
Air flow free air	m ³ /h	900	1250	1550
Air flow at 400 mbar/60% vacuum	m ³ /h	860	1210	1470
Maximum vacuum	%	95	95	95
Max vacuum continuous duty	%	80	80	80
Power required at 0,5 bar rel. (1,5 abs.)	kW	28	39	48
Max operating rel. pressure (abs.)	bar	1 (2)	1 (2)	1 (2)
Sound pressure level at 7 m and 60% vacuum	dBA	75	74	78
Weight	kg	345	445	530
Oil consumption	g/h	210	250	330
Oil tank capacity	l	11	13	13
Mass moment of inertia	kgm ²	0,57	0,96	1,30
Heat to be dissipated	kcal/h	8.000	11.000	12.000
Circulating pump flow rate	l/min	50	70	80
Circulating pump speed	min ⁻¹	2.600	3.000	2.800

Lubrification

Manufacturer	AGIP	ESSO	SHELL	ELF	MOBIL	BP
Summer	ISO VG 150 Radula 150	Nurray 150	Vitrea 150	Movixa 150	Rubrex 900	Energol CS 150
Winter	SAE 10W SAE 20W	Diesel Sigma S 10W20 Essolube HDX 20W20	Rimula X Oil 10W	Tractorelf ST3 20W20	Delvac 1310 10W	Vanellus C3 20W

Flow rate/pressure

Power/pressure

PR 150

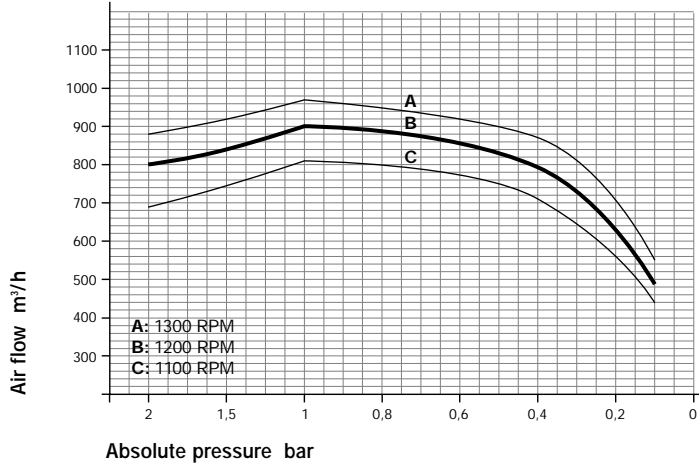

PR 150

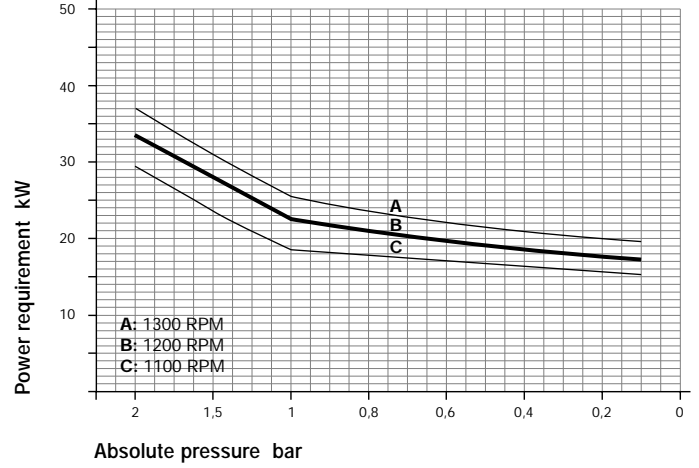

PR 200

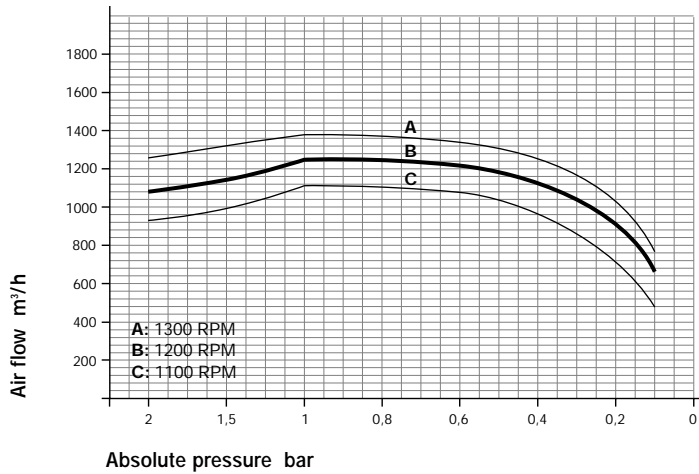

PR 200

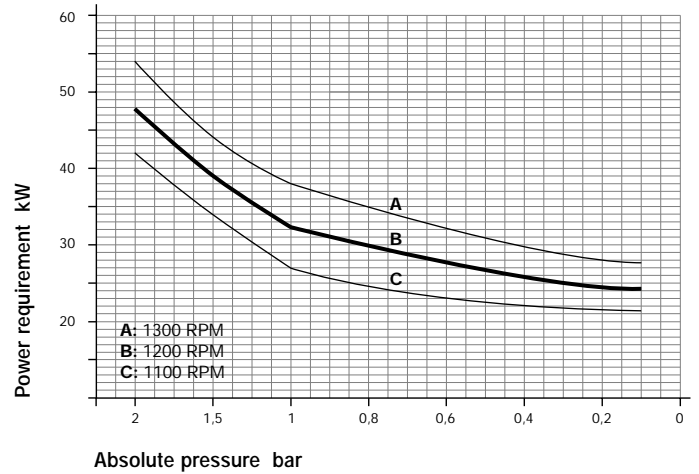

PR 250

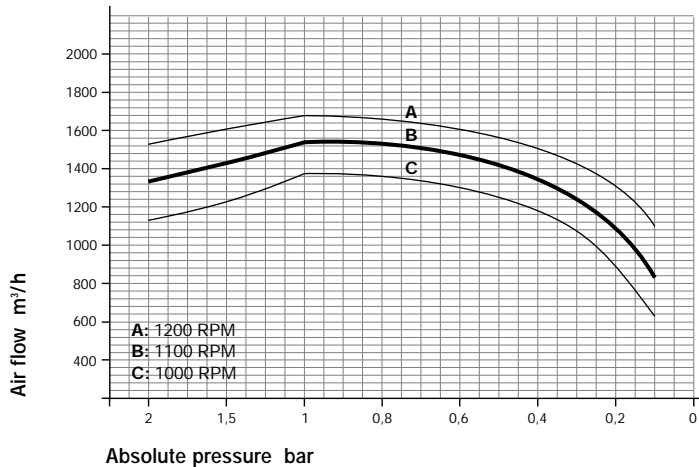

PR 250

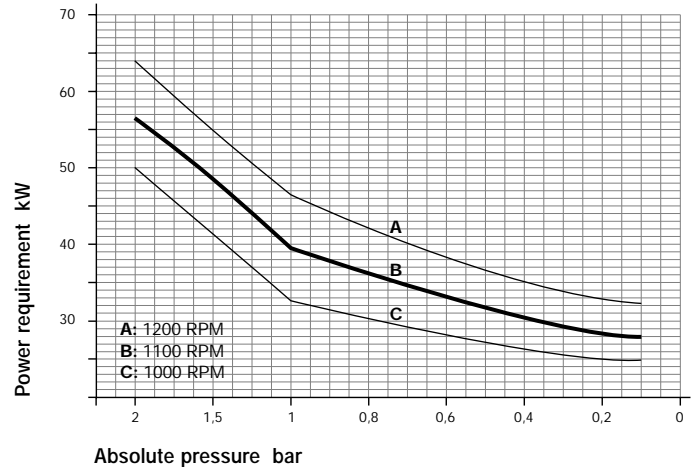

Sound pressure level

PR 150

fig. 1

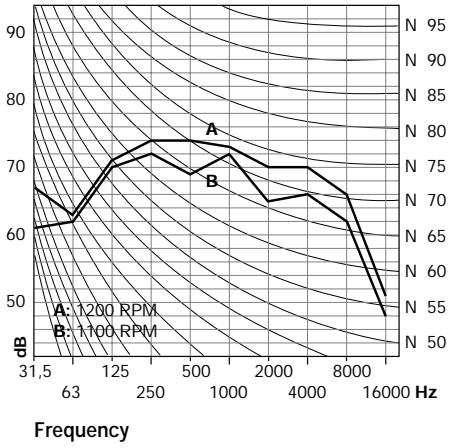

PR 200

fig. 2

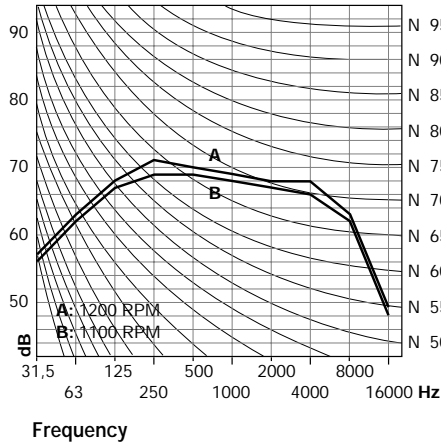

PR 250

fig. 3

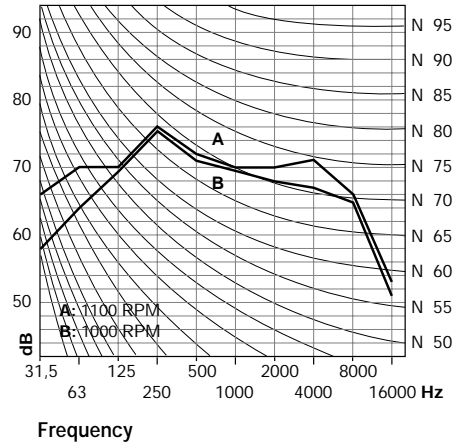

■ The diagrams (fig. 1-2-3) show the sound analysis of PR vacuum pumps measured at 456 mm Hg (60% vacuum) at 7 m distance for different rotation speed. In such conditions the reference value is:

PR150	1.100 r.p.m.	72 dBA
	1.200 r.p.m.	75 dBA
PR200	1.100 r.p.m.	72 dBA
	1.200 r.p.m.	74 dBA
PR250	1.000 r.p.m.	76 dBA
	1.100 r.p.m.	78 dBA

To have the sound level for different distances and/or vacuum rates add the **correction factor** from fig. 4 to the reference value.

Example: PR150 a 1.100 g/min., 30% vacuum and 4 m: 72+6=78 m.

Correction factor

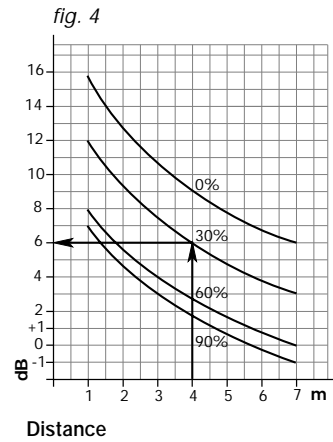

Water recycling pump

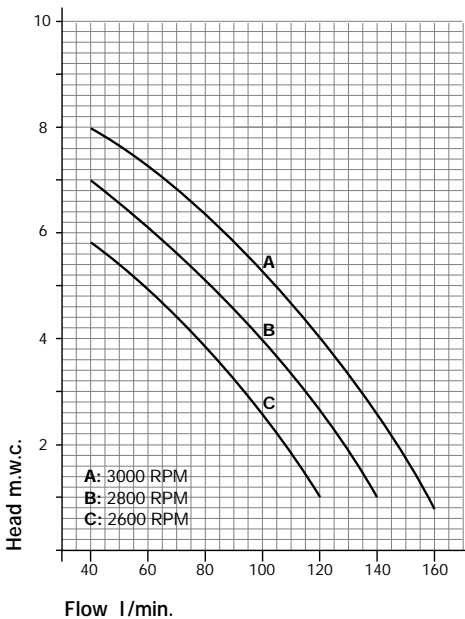

Evacuation times

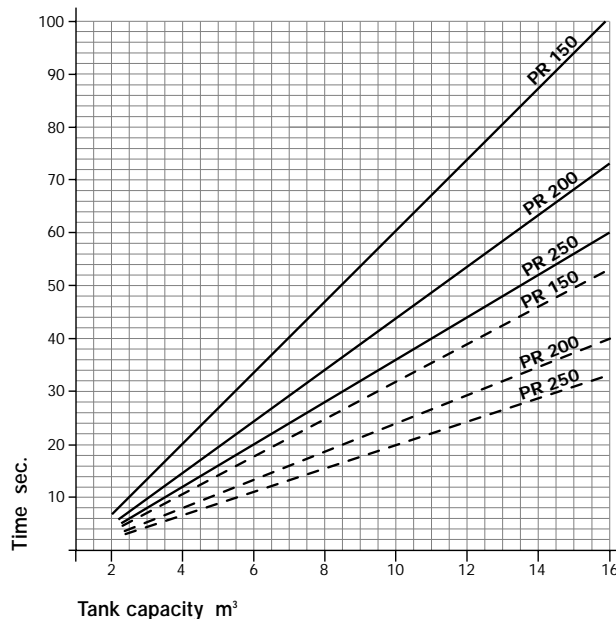

■ The diagram gives the evacuation time for a tank of a stated capacity. The actual time is affected by the air tightness of the whole vacuum system.

2 Installation

NOTE *The following indications are valid for mobile installation on trucks and anyhow must be followed also for stationery applications.*

2.1 Initial check

Upon receiving the pump, check if it has been damaged during the delivery.

Positioning

The pump must be placed on the vehicle so that it can be easily reached for maintenance.

Drive and alignment

The pump can be driven either mechanically by cardan shaft, belts and pulley or by hydraulic motor.

The cardan shaft must be mounted so that it does not create axial thrust and a flexible joint must be used; the inclination of the shaft must not exceed 15° (see fig. 3).

When using the belts and pulley, the pulley can be mounted directly on the rotor shaft (see fig. 2).

The alignment between the pulley of the pump and the driving pulley must be thoroughly checked.

The V-belts tension must be normal, which means that the belts must flex for about 2 cm. under the thumb pressure (see fig. 3).

With the hydraulic transmission the motor must be mounted by means of a support and a flexible joint. (see fig. 1)

When mounting the pump on a vehicle, it must be fixed to the chassis by a suitable stand.

Check that the rotation is the same shown on the pump.

NOTE *Rotation speed must not exceed the suggested value (see page 4-5).*

The rubber pipelines of the vacuum line must be of oil and corrosion-resistant material.

Before connecting the pipeline be sure that the inside is clean. Draining taps must be placed on the lowest part of the suction connection in order to drain the condensation.

When first running the pump, or after a long period of inactivity, or after operating in a dusty environment the pump must be washed out by introducing about 2 litres of diesel fuel through the inlet port.

NOTE *This operation must last not more than 30". If necessary repeat such operation after 10'*

2.2 Protection of the inlet port

In order to avoid solid parts to enter the pump a filter with stainless steel mesh of 300 micron filtration capacity must be mounted on the suction line just in front of the inlet port in an accessible position. (see fig. 1-2 Pos. 5)

2.3 Protection against intake of liquids

In order to avoid the intake of liquids, the pump must be protected by a primary shutoff mounted on top of the tank and a secondary shutoff mounted along the suction line both with an overflowing device. The air passage must be at least equivalent to that of the suction line. (see fig. 1-2 Pos. 1-2)

2.4 Non-return check valve

A non-return check valve must be placed along the suction line in between the pump and the 4 way valve. Be sure that such valve opens according to the flow direction and that the air passage is at least equivalent to that of the suction pipeline. (see fig. 1-2 Pos. 4)

2.5 4 way valve

If the 4 way change-over valve is driven by a pneumatic cylinder, the stroke must be exactly adjusted, so that the valve cock stops at the exact position, at the end of the stroke. (see fig. 1-2 Pos. 3)

2.6 Exhauster/Oil separator

The noise made by the pump must be reduced by a silencer placed along the discharge line, as close as possible to the outlet of the pump. It must be adequate for the air flow of the vacuum pump. The oil used for lubricating the vacuum pump must be separated by means of a suitable oil separator (normally built in the exhauster). Such oil separator must be drained by means of a tap which has to be checked daily (see Pos. 7 - Fig. 1-2).

2.7 Cooling of the pump

The cooling system consists of a centrifugal recycling pump (see performances at pag. 4÷6) supplied together with the vacuum pump, of a heat exchanger c/w fans suitable for dissipating the heat generated by the system (see pag. 4) and of an expansion tank. The temperature of the cooling media must not exceed 60° C. The heat exchanger must be placed so that the air can stream freely.

The use of antifreeze glicole is suggested.

2.8 Pressure relief valve

A pressure relief valve capable of discharging the whole flow of air of the pump must be placed in between the tank and the vacuum pump.

The valve must be adjusted at a discharge pressure not more than 10% higher than the operating pressure of the vacuum pump and anyhow not higher than the operating pressure of the tank.

2.9 Vacuum relief valve

The vacuum relief valve has the function of keeping the operating vacuum rate below that designed as the maximum for the pump.

(The installation of such valve is not strictly needed for the running of the pump, but if the vacuum relief valve is not mounted, make sure that the cooling system is properly dimensioned).

Upon reaching the adjusted vacuum rate, the valve opens allowing the pump to intake atmospheric air.

The valve must be placed along the suction line.

NOTE *For continuous duty operating of the vacuum pump at vacuum rates and performances close to the maximum limits please contact Jurop's Technical Department.*

Layout of a hydraulic drive for Mod. PR150-200-250

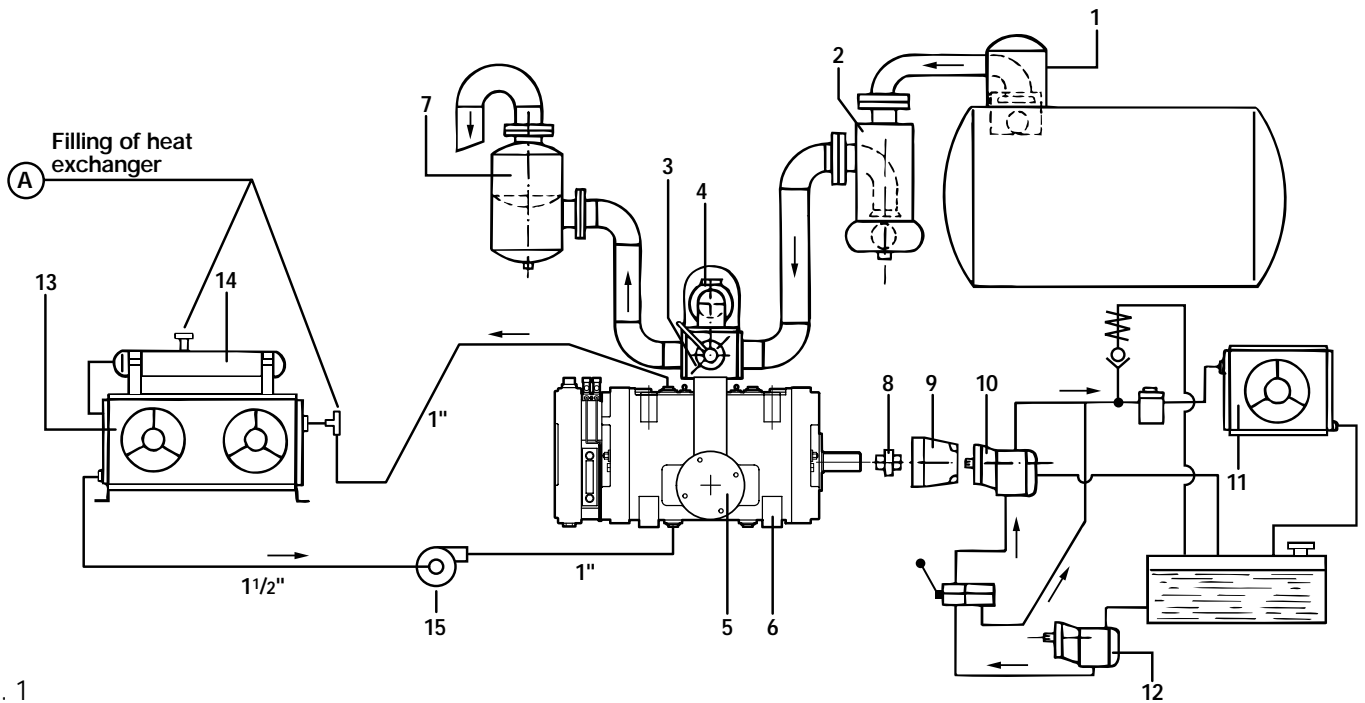

Fig. 1

Installation					
Components	Pos.	PR150 Code	PR200 Code	PR250 Code	Description
Vacuum line	1	18450.001.00	18450.001.00	18450.001.00	Primary shutoff
	2	14450.020.00	14450.025.00	14450.025.00	Secondary shutoff cyclone
	3	14881.009.00	14881.010.00	14881.010.00	4 way valve pneum.
	4	14933.008.00	14933.009.00	14933.009.00	Check valve
	5	14450.029.00	14450.032.00	14450.032.00	Air filter
	6	A2908.001.30	A2708.001.30	A2808.001.30	Vacuum pump c.w.
	7	15470.014.00	15470.014.00	15470.017.00	Silencer/Oil separator
Transmission	8	14701.018.00	14701.019.00	14701.019.00	Coupling
	9	16125.025.00	16125.024.00	16125.024.00	Hydromotor mounting flange
	10	4024.1070.04	40241.070.03	4024.1070.07	Hydraulic motor
	11	4021.5010.31	4021.5010.31	4021.5010.41	Air-oil cooler
	12	4024.2050.04	4024.2050.09	4024.2050.03	Hydraulic pump
Cooling	13	4021.5010.22	4021.5010.22	4021.5010.12	Air-water cooler
	14	14873.002.00	14873.002.00	14873.002.00	Expansion tank
	15	14072.008.00	14072.008.00	14072.008.00	Water recycling pump c.w.

Mechanical transmission of Mod. PR150 - 200 - 250

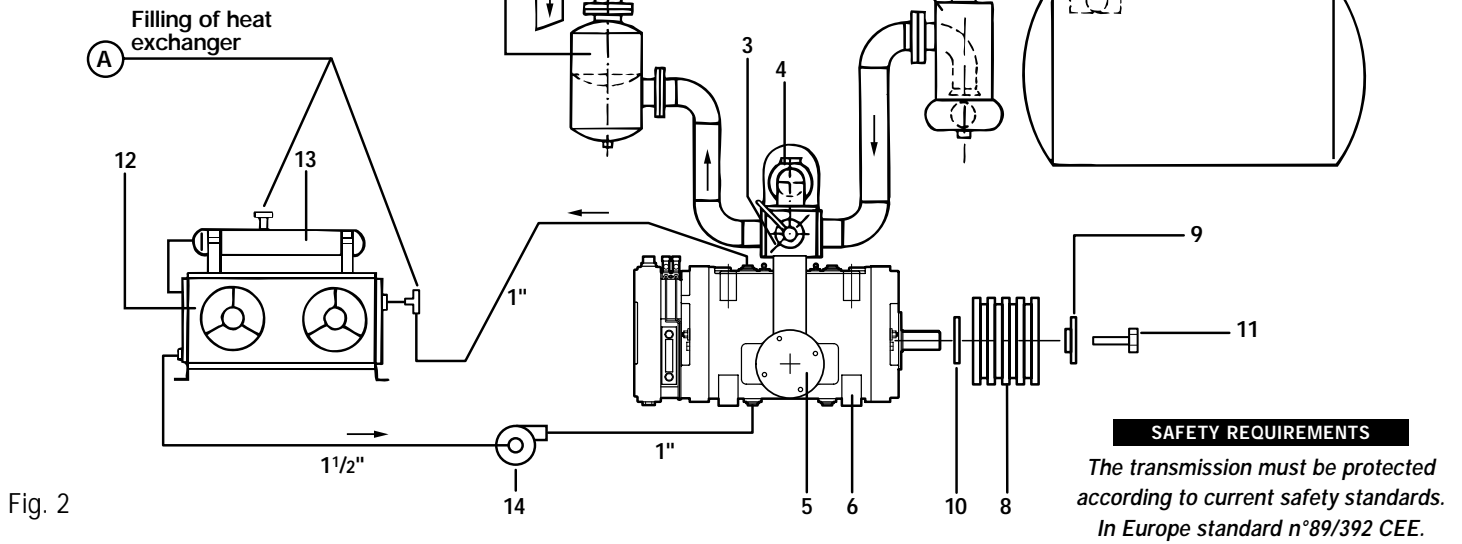

Fig. 2

Installation					
Components	Pos.	PR150 Code	PR200 Code	PR250 Code	Description
Vacuum line	1	18450.001.00	18450.001.00	18450.001.00	Primary shutoff
	2	18440.007.00	18440.007.00	18440.007.00	Secondary shutoff
	3	14881.009.00	14881.010.00	14881.010.00	4 way valve
	4	4027.4003.09	4027.4003.09	4027.4003.09	Check valve
	5	14450.002.00	14450.005.00	14450.004.00	Air filter
	6	A2908.001.30	A2708.001.30	A2808.001.30	Vacuum pump c.w.
	7	15470.013.00	15470.016.00	15470.016.00	Silencer/Oil separator
Transmission	8	16535.023.00	16525.024.00	16535.024.00	Pulley
	9	16850.036.00	16850.037.00	16850.037.00	Fixing washer
	10	16240.137.00	16240.138.00	16240.138.00	Keep plate
	11	4026.1074.14	4026.1074.14	4026.1074.14	Screw M 14x40
	Cooling	12	4021.5010.21	4021.5010.21	4021.5010.11
13		14873.002.00	14873.002.00	14873.002.00	Expansion tank
14		14072.008.00	14072.008.00	14072.008.00	Water recycling pump c.w.

SAFETY REQUIREMENTS

The transmission must be protected according to current safety standards. In Europe standard n. 89/392 CEE.

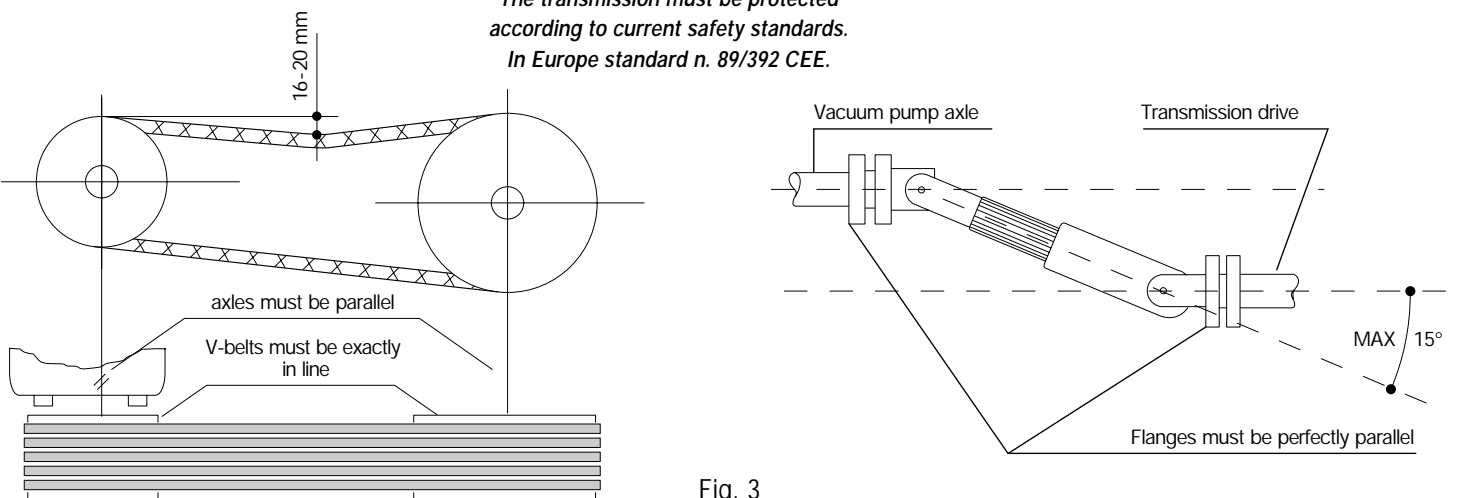

Fig. 3

3 First running of the system

Legend:

- 1 Water recycling pump
- 2 Vent of pump housing and flanges
- 3 Cooling liquid outlet
- 4 Water filling tap
- 5 Vanes inspection port
- 6 Oil filling tap
- 7 Oil tank
- 8 Oil sight glass
- 9 Oil tank drain
- 10 Cooling liquid inlet
- 11 Draining tap of pump housing

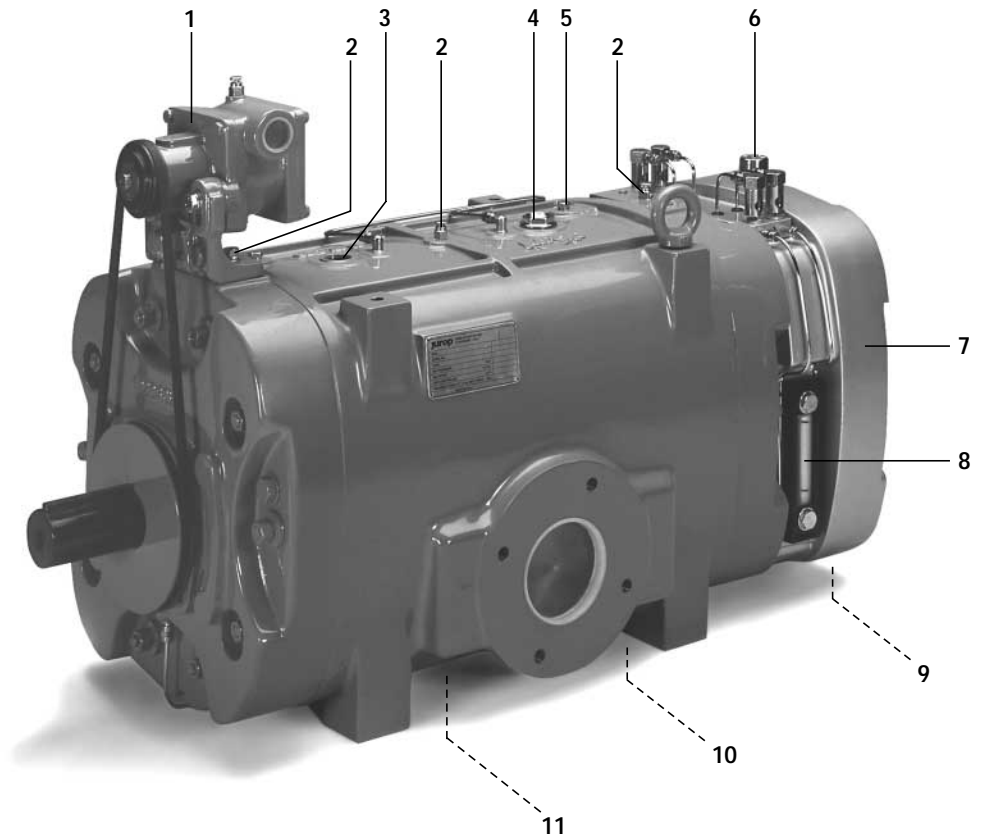

Fig. 4

Attention:

The suction line and the vacuum tank must be provided with safety valves. To alter the adjustment of such valves may cause serious damage or danger of explosion.

3.1 Fill the oil tank up to about 3 cm. below the filling tap - Pos. 6 - Fig. 4.

For the selection of the lubricating oil see Pag. 4.

3.2 After releasing the vent taps Pos. 2 - Fig. 4 overfill the pump housing with the cooling media through the tap of Pos. 4 - Fig. 4.

Fill up the heat exchanger through the taps shown at point A of the installing layouts of Pag. 8-9 - pos. A.

The expansion tank must be half filled, checking the level through the sight glass.

Screw on all the filling taps and vents.

The whole cooling system as shown has an approximate capacity of 30÷50 l. for the PR 150÷250.

During the wintertime antifreeze glicole must be added with the following percentages:

- 20% down to minus 10° C
- 35% down to minus 20° C
- 50% down to minus 30° C

Important:

Vent with care both the vacuum pump and the whole system.

3.3 Open all the valves of the vacuum system.

3.4 Check the correct rotation and run the pump for a few seconds.

3.5 While the pump is running check the following:

- a) The oil must drip inside the oilers.
(25÷30 drops per minute at the suggested pump speed)
- b) The rate of vacuum and pressure.

3.6 The oil pump is adjusted during the assembling of the vacuum pump.

For the flow see the performance chart at Pag. 4.

4 Maintenance of the vacuum pump

4.1 Lubrication

Check time by time through the sight glass of the drip oilers that the drops of oil flow regularly.

If this does not happen stop the pump immediately and check the oil level and the oil pump.

Drain daily the oil from the exauster/oil separator. Do not re-use such oil.

If the vacuum pump happens to run without lubrication it will heat up and could consequently be damaged.

In case of field adjustment of the oil flow see the following instructions and in case contact **Jurop's** Technical Departments:

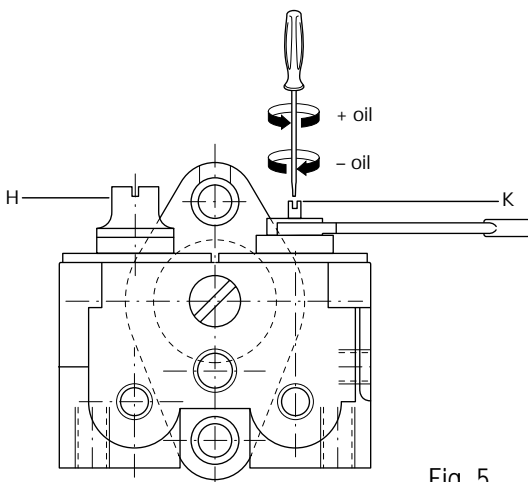

Fig. 5

- Screw of the filling and draining taps of Pos. 1-3 - Fig. 4.
- Unscrew the screws fixing the access flange of the oil tank.
- Take off the protection caps "H" of fig. 5
- With a short screw driver and spanner screw or unscrew the plug "K" of Fig. 5.
- Reset everything and fill up with oil.

NOTE Never reduce the oil flow which is shown at pag. 4.

4.2 Performance control

Check time by time the vacuum rate of the pump.

If it does not reach the nominal value, it means that there could be wear of inside parts.

Proceed immediately with the measure of the vanes wear and with a thorough cleaning of the inside of the vacuum pump. (see points 4.4 and 4.5)

4.3 Temperature of the cooling liquid

The temperature of the cooling liquid should never exceed 60° C. If this happens check the whole cooling system and the operating of the vacuum pump.

4.4 Intake of liquids

In case of malfunction of the primary or secondary shutoff some liquid could flow from the tank into the vacuum pump. In this case the pump must be washed out by sucking about 2 l. of diesel fuel through a suitable tap placed on the suction line. Run the pump, shut off the tap and check the performances of the pump.

NOTE This operation must last not more than 30". If necessary repeat such operation after 10'.

Drain the diesel fuel from the oil trap of the exauster after the cleaning.

4.5 Checking the wear of the vanes

The wear of the vanes can be checked without taking apart the pump.

Unscrew the plug Pos. 5 -Fig. 4 and insert a rod of dia. 6 mm. and turn the shaft by hand. With the checking rod touching the outside diameter of the rotor, mark it a first time with a scriber (The rod is supplied with the pump).

Continue turning the shaft till the checking rod falls inside a vane groove touching the vane.

Mark the rod a second time. If the distance between the two marks exceeds 10 mm. the vanes must be replaced (see Fig. 6).

Once finished the checking procedure replace the plug Pos. 5.

NOTA «Min» e «max» marks are already traced on the rod supplied with the pump.

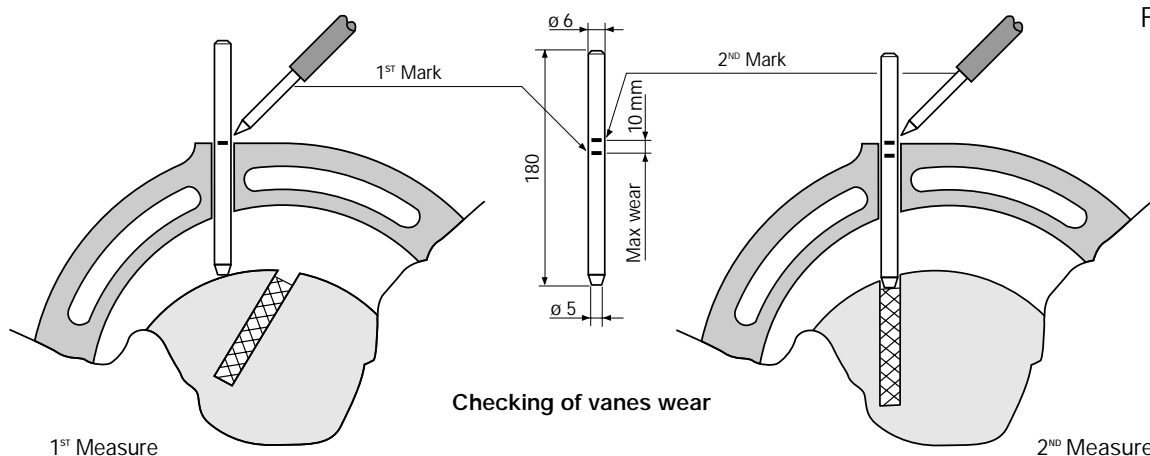

Fig. 6

4.6 Replacement of the vanes

When replacing the vanes proceed as following (fig. 7):

- a) Drain the cooling liquid from the pump housing (Pos. 11 - Fig. 4).
- b) Remove the lubrication pipeline Pos. 27.
- c) Remove the key Pos. 96.
- d) Unscrew all the nuts Pos. 78 and take off the flange Pos. 8.
- e) Pull out the vanes Pos. 4 and clean the grooves of the rotor.
- f) Replace the vanes and lubricate them thoroughly.
- g) Replace the gasket Pos. 35
- h) Assemble all the parts taking care to lubricate all the gaskets (pos. 47-48) and the bearing. Align the flange by the steady pins (pos. 92) supplied with the pump.
- i) Tighten the nuts pos. 78 by means of a dynamometric wrench adjusted at 88 Nm and pull out the N° 2 steady pins.
- l) Refill the cooling system as shown at Pag. 10 - Paragraph 3.2 and re-install the pipeline pos. 27.

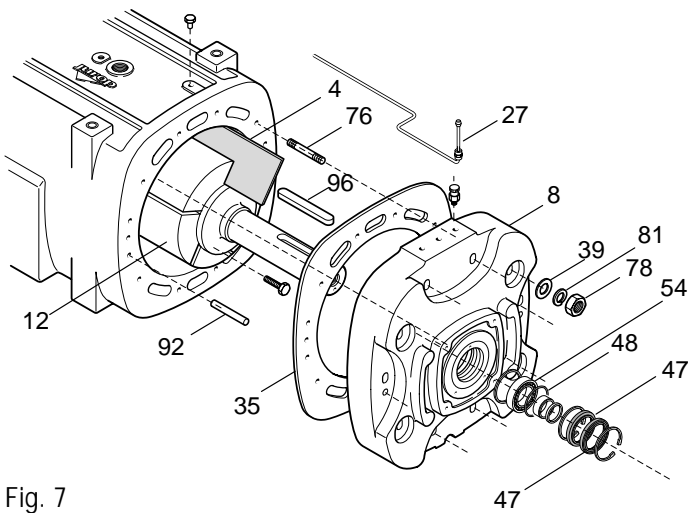

Fig. 7

4.7 Cleaning of suction filter

For weekly maintenance or in case of intake of liquid operate as follows (fig. 8):

- a) Remove the filtering cartridge
- b) Clean with detergent or diesel fuel and with a jet of air.
- c) When replacing the lid taking care of the exact positioning of the o-ring gasket

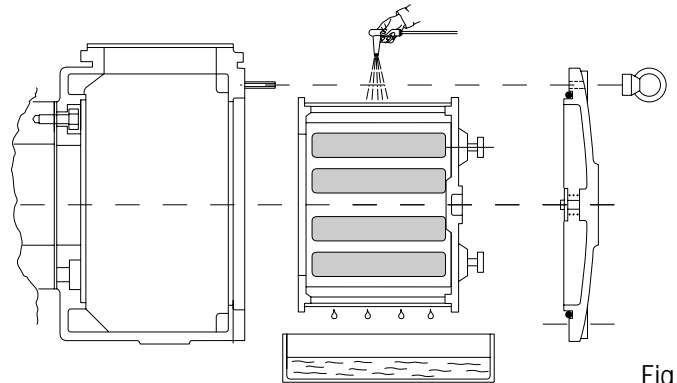

Fig. 8

4.8 Preliminary maintenance

Operation	Daily	Weekly	Quarter
Oil level checking	•		
Pressure and vacuum checking	•		
Pressure relief valve control		•	
Cooling media temperature control	•		
Cleaning of suction filter		• (1)	
Wear of vanes			•

(1) And in case of liquid intake

5 Spare parts list

5.1 How to order the spare parts

To avoid mistakes when ordering the spare parts make sure you indicate:

- a) The model of the pump. } See pump label
- b) The serial number of the pump. }
- c) The denomination of the part. }
- d) The number of pieces. } See spare parts list
- e) The code of the part. }

Example:

- a) PR150
- b) X70012
- c) Vane
- d) N. 6 pieces
- e) 1601605000

4.9 Trouble-shooting

TROUBLES

A. The pump overheats	
Cause	Correction
• Faulty lubrication.	• Check the lubrication system and the oil pump.
• Oil missing.	• Re-fill the tank.
• Revolutions too high.	• Reduce revolutions.
• Operation-time too long at too high vacuum.	• Operate at lower vacuum rate (See point 2.9 - pag. 7).
• Reduced cooling.	• Check the performances of the centrifugal water recycling pump, the correct design and efficiency of the heat exchanger and check and vent thoroughly the whole cooling system.

B. The pump does not run	
Cause	Correction
• Broken vanes due to suction of foreign objects or bad lubrication or excess of wear.	• Take apart the pump and replace damaged parts. Check primary shut-off and lubrication system.
• Frozen pump.	• Unfreeze the vacuum pump.
• Damaged drive system.	• Check and replace damaged parts.

C. Reduced performances of the pump (vacuum/pressure/air flow)	
Cause	Correction
• Change-over 4 way valve in neutral position.	• Check position of inside baffle (cock) and manual lever or pneumatic actuator.
• Worn sliding-vanes.	• Replace the vanes.
• Loose check-valve.	• Replace the valve.
• Worn sealing rings.	• Replace the rings.
• Blocked vacuum pump.	• See previous instructions (point B).
• Leaking of the gate-valves of the tank.	• Tighten the valves or replace them.
• Leaking of the seals of the tank.	• Repair or replace the seals.
• Primary shut-off blocked.	• Dismount and clean the parts.
• Clogged connecting pipeline	• Clean the steel pipelines or replace the rubber ones.
• The suction filter is clogged	• Clean the cartridge.
• Accessories and whole vacuum line undersized	• Check the design according to the maximum performances of the vacuum pump (see pag. 4).

5.2 Part list layout
Mod. PR 150

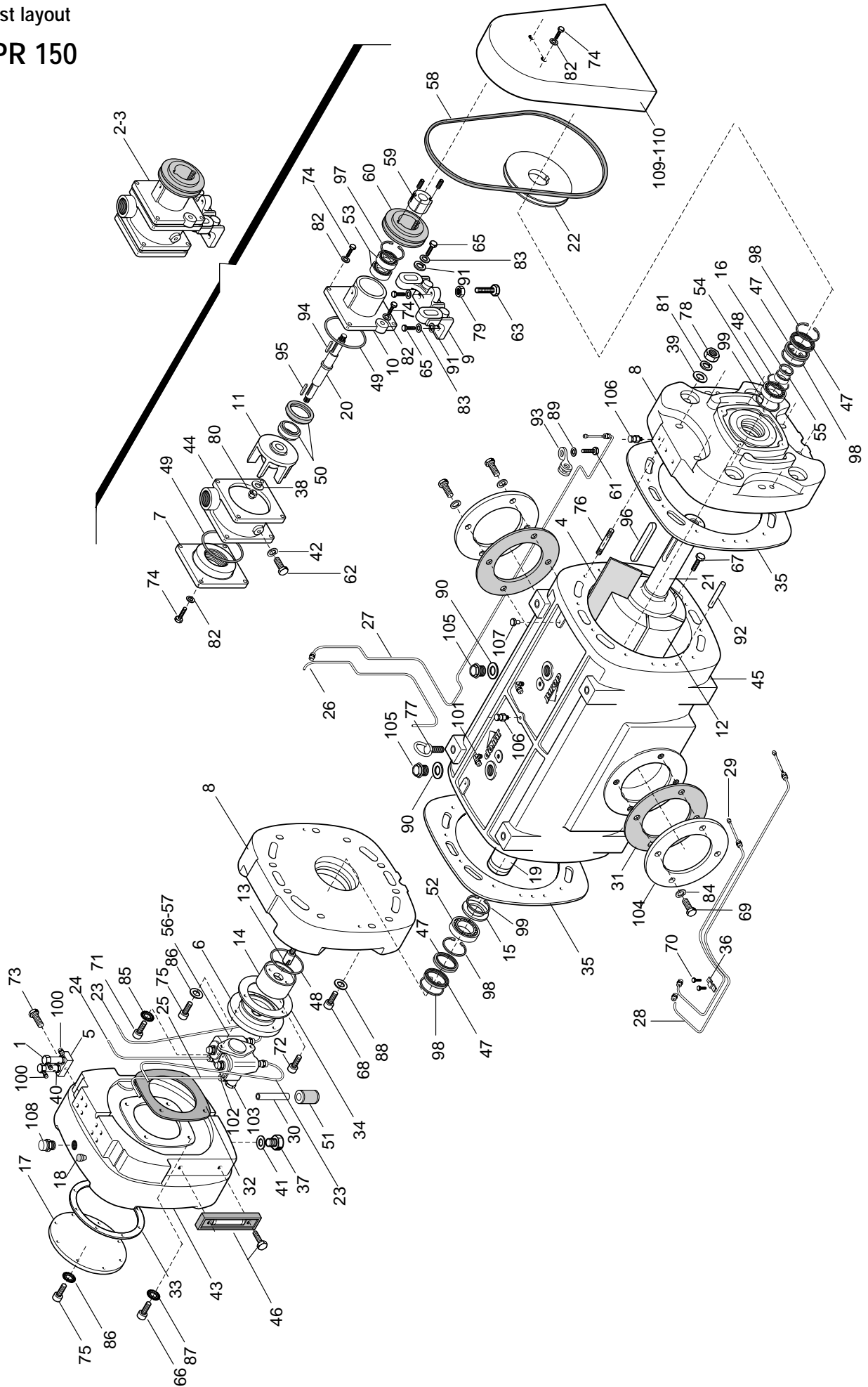

Part list mod. PR 150

Pos.	Code	Description	Qty	Pos.	Code	Description	Qty
1	1401200700	Drip oiler	4	57	4024250500	Oil pump 4 outlets CCW	1
2	1407200800	Water recycling pump cw	1	58	4025350021	Belt SPZ 975 texrope	1
3	1407200900	Water recycling pump ccw	1	59	4025422300	Cone bushing 2820 Ø 16	1
4	1601605000	Vane PR150	6	60	4025422402	Pulley SPZ 71x1	1
5	1608100600	Oil block	2	61	4026101301	Screw 4.8 M 6x10	1
6	1610015200	Oil pump flange	1	62	4026101403	Screw 4.8 M 8x10	1
7	1610506500	Water pump rear flange	1	63	4026102914	Screw 8.8 M 10x60	1
8	1610506900	End plate	2	65	4026107214	Screw 8.8 M 10x40 5739	4
9	1613500900	Water pump support bracket	1	66	4026107311	Screw 8.8 M 12x30 5739	4
10	1613501000	Water pump front flange	1	67	4026107212	Screw 8.8 M 10x35 5739	12
11	1621502800	Water pump impeller	1	68	4026107306	Screw 8.8 M 12x16	4
12	1621503100	Vacuum pump PR 150 rotor	1	69	4026107514	Screw 8.8 M 16x40	8
13	1622004100	Oil pump pivot	1	70	4026120100	Screw 8.8 M 4x8	2
14	1624013300	Oil pump drive bushing	1	71	4026120300	Screw 8.8 M 6x14 5931	2
15	1624013400	Spacer 85x72x4	1	72	4026120303	Screw 8.8 M 6x20 5931	2
16	1624013200	Spacer 52x45x4	1	73	4026120306	Screw 8.8 M 6x30	2
17	1640100900	Oil tank lid	1	74	4026120401	Screw 8.8 M 8x16	10
18	1642600000	Oil line protection	4	75	4026120403	Screw 8.8 M 8x20 5931	11
19	1650010900	Rear shaft PR150	1	76	4026171117	Stud screw 8.8 M 10x80	20
20	1650009700	Water pump shaft	1	77	4026190002	Eye bolt M 16	2
21	1650010800	Front shaft PR150	1	78	4026301601	Nut M10 5587	20
22	1653502100	Water pump pulley SPZ 150x1	1	79	4026308006	Nut M10 5588	1
23	1663031600	Oil line pump/drip oiler	2	80	4026322106	Nut M12 sp.	1
24	1663031700	Oil line pump/drip oiler	1	81	4026350506	Grower washer 10	20
25	1663031800	Oil line pump/drip oiler	1	82	4026350505	Grower washer 8	10
26	1663031900	Oil line rear bearing	1	83	4026350608	Grower washer 10 1751	4
27	1663032000	Oil line front bearing	1	84	4026350611	Grower washer 16 1751	8
28	1663032100	Oil line housing front	1	85	4026350908	Washer M 6 6798	2
29	1663032200	Oil line housing rear	1	86	4026350909	Washer M 8 6798	11
30	1663032300	Oil line suction pipe Ø 6	1	87	4026350911	Washer M 12	4
31	1680607200	Inlet/outlet gasket	2	88	4026356107	Flat washer M 12	4
32	1680607300	Oil tank gasket	1	89	4026357003	Flat washer M 6	1
33	1680706100	Oil lid gasket	1	90	4026359001	Washer 40x33,5x1,5 AL	3
34	1680705900	Oil pump flange gasket	1	91	4026366106	Flat washer M 10	4
35	1680706000	Housing gasket	2	92	4026401812	Pin 10x60 M 6	4
36	1682000800	Pipeline fixing strip	1	93	4026426703	Rubber strip Ø 6,5	1
37	1684000000	Oil draining tap 3/8"	1	94	4026500605	Tab 5x5x18	1
38	1685002400	Safety washer	1	95	4026500609	Tab 5x5x28	1
39	1685003500	Washer 35x10,5x6	20	96	4026501508	Tab 14x9x90	1
40	1685100000	Drip oiler washer AL 14X20X1,5	4	97	4026510525	Seeger ring I 42 7437	1
41	1685100200	Flat washer AL 17X22X1,5	1	98	4026510540	Seeger ring I 72 7437	4
42	1685100800	Washer Ø 8 AL	1	99	4026510545	Seeger ring I 85 7437	2
43	1687100900	Oil tank	1	100	4026702000	Univ. connection 4x1/8" 1050	12
44	1687504500	Water pump housing PR	1	101	4026706001	Univ. connection 90° 4x1/4" 1020	2
45	1687505100	PR 150 housing	1	102	4026706101	Pivot connection 4x1/8" 1170	2
46	4022106001	Oil sight glass	2	103	4026706104	Pivot connection 6x1/8" 1170	1
47	4022200052	Seal ring 52x72x10	4	104	4026713006	Inlet/outlet flange UNI2276 DN 80	2
48	4022200212	OR 2162	2	105	4026904003	Plug 1"	2
49	4022200235	OR 4325	2	106	4026904300	Venting valve 1/4"	4
50	4022216915	Water pump mech. seal	1	107	4026905002	Plug 1/4"	4
51	4022300001	Nylon filter Ø 6	1	108	4026910004	Oil tank plug 1"	1
52	4023100045	Bearing 6209/C3	1	109	1642003300	Mech. transmission cover	1
53	4023100516	Bearing 6004 RS1	2	110	1642003400	Hydr. transmission cover	1
54	4023110048	Bearing 2209 NU ECP/C3	1				
55	4023130032	Bushing 52x45x40 IR	1				
56	4024250000	Oil pump 4 outlets CW	1				

5.3 Part list layout
Mod. PR 200

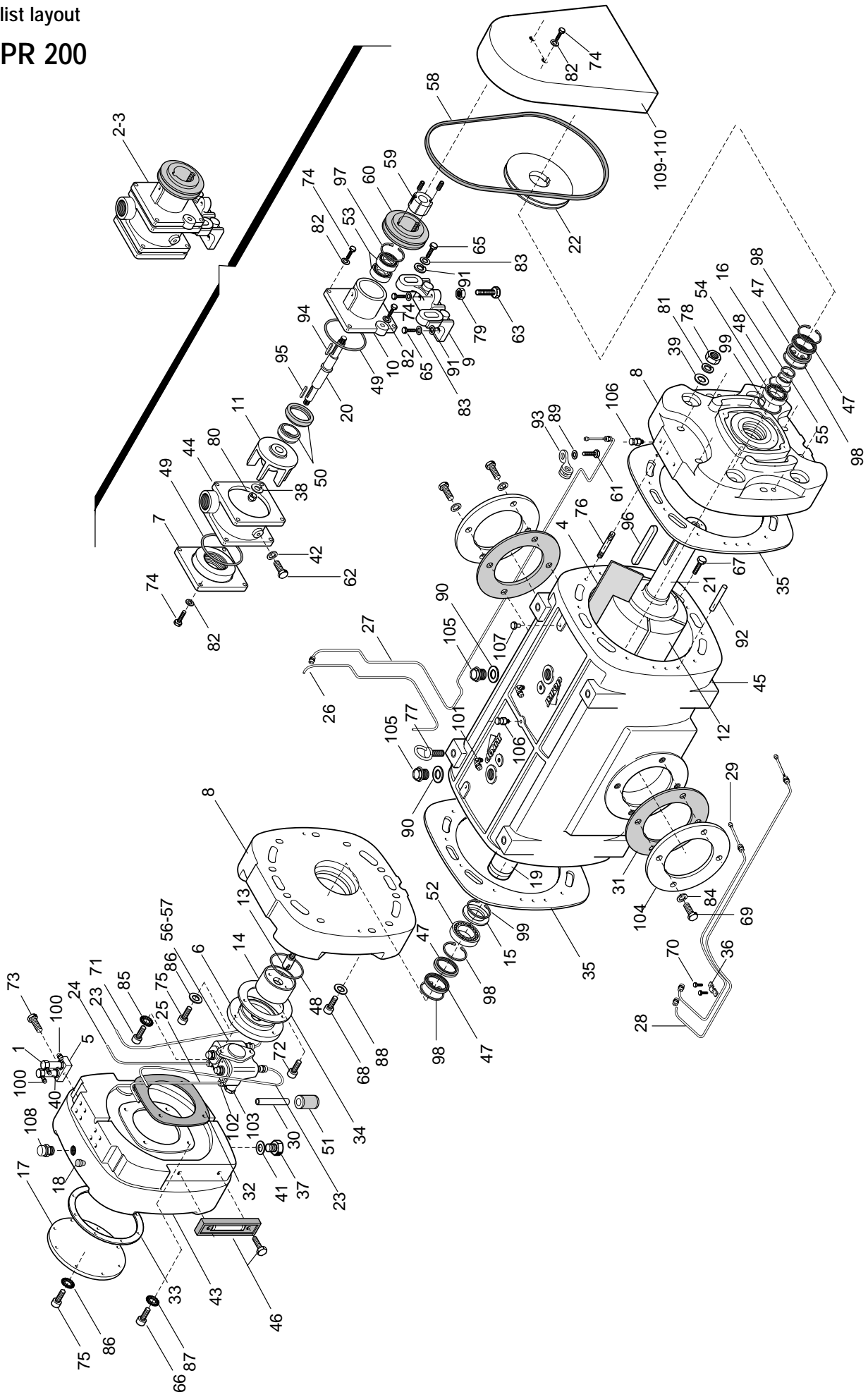

Part list mod. PR 200

Pos.	Code	Description	Qty	Pos.	Code	Description	Qty
1	1401200700	Drip oiler	4	57	4024250500	Oil pump 4 outlets CCW	1
2	1407200800	Water recycling pump cw	1	58	4025350024	Belt SPZ 1060 texrope	1
3	1407200900	Water recycling pump ccw	1	59	4025422300	Cone bushing 2820 Ø 16	1
4	1601604900	Vane PR 200	6	60	4025422402	Pulley SPZ 71x1	1
5	1608100600	Oil block	2	61	4026101301	Screw 4.8 M 6x10	1
6	1610015000	Oil pump flange	1	62	4026101403	Screw 4.8 M 8x10	1
7	1610506500	Water pump rear flange	1	63	4026102914	Screw 8.8 M 10x60	1
8	1610506600	End plate	2	65	4026107214	Screw 8.8 M 10x40 5739	4
9	1613500900	Water pump support bracket	1	66	4026107311	Screw 8.8 M 12x30 5739	4
10	1613501000	Water pump front flange	1	67	4026107312	Screw 8.8 M 12x35 5739	12
11	1621502800	Water pump impeller	1	68	4026107306	Screw 8.8 M 12x16	4
12	1621502900	Vacuum pump PR 200 rotor	1	69	4026107514	Screw 8.8 M 16x40	8
13	1622004100	Oil pump pivot	1	70	4026120100	Screw 8.8 M 4x8	2
14	1624009600	Oil pump drive bushing	1	71	4026120300	Screw 8.8 M 6x14 5931	2
15	1624009700	Spacer 100x84x3,9	1	72	4026120303	Screw 8.8 M 6x20 5931	2
16	1624010300	Spacer 65x55x10	1	73	4026120306	Screw 8.8 M 6x30	2
17	1640100800	Oil tank lid	1	74	4026120401	Screw 8.8 M 8x16	10
18	1642600000	Oil line protection	4	75	4026120403	Screw 8.8 M 8x20 5931	11
19	1650006800	Rear shaft PR200/PR250	1	76	4026171211	Stud screw 8.8 M 12x80	20
20	1650009700	Water pump shaft	1	77	4026190002	Eye bolt M 16	2
21	1650010700	Front shaft PR200/PR250	1	78	4026301603	Nut M12 5587	20
22	1653502000	Water pump pulley SPZ 180x1	1	79	4026308006	Nut M10 5588	1
23	1663030400	Oil line pump/drip oiler	2	80	4026322106	Nut M12 sp.	1
24	1663030600	Oil line pump/drip oiler	1	81	4026350508	Grower washer 12	20
25	1663030700	Oil line pump/drip oiler	1	82	4026350505	Grower washer 8	10
26	1663030800	Oil line rear bearing	1	83	4026350608	Grower washer 10 1751	4
27	1663030900	Oil line front bearing	1	84	4026350611	Grower washer 16 1751	8
28	1663031000	Oil line housing front	1	85	4026350908	Washer M 6 6798	2
29	1663031100	Oil line housing rear	1	86	4026350909	Washer M 8 6798	11
30	1663031500	Oil line suction pipe Ø 6	1	87	4026350911	Washer M 12	4
31	1680604700	Inlet/outlet gasket	2	88	4026356107	Flat washer M 12	4
32	1680607100	Oil tank gasket	1	89	4026357003	Flat washer M 6	1
33	1680705600	Oil lid gasket	1	90	4026359001	Washer 40x33,5x1,5 AL	3
34	1680705700	Oil pump flange gasket	1	91	4026356106	Flat washer M 10	4
35	1680705800	Housing gasket	2	92	4026401812	Pin 10x60 M 6	4
36	1682000800	Pipeline fixing strip	1	93	4026426703	Rubber strip Ø 6,5	1
37	1684000000	Oil draining tap 3/8"	1	94	4026500605	Tab 5x5x18	1
38	1685002400	Safety washer	1	95	4026500609	Tab 5x5x28	1
39	1685002700	Washer 35x13x6	20	96	4026501212	Tab 16x10x110	1
40	1685100000	Drip oiler washer AL 14x20x1,5	4	97	4026510525	Seeger ring I 42 7437	1
41	1685100200	Flat washer AL 17x22x1,5	1	98	4026510547	Seeger ring I 90 7437	4
42	1685100800	Washer Ø 8 AL	1	99	4026510551	Seeger ring I 100 7437	2
43	1687100800	Oil tank	1	100	4026702000	Univ. connection 4x1/8" 1050	12
44	1687504500	Water pump housing	1	101	4026706001	Univ. connection 90° 4x1/4" 1020	2
45	1687504700	PR 200 housing	1	102	4026706101	Pivot connection 4x1/8" 1170	2
46	4022106001	Oil sight glass	2	103	4026706104	Pivot connection 6x1/8" 1170	1
47	4022200072	Seal ring 65x90x10	4	104	4026713007	Inlet/outlet flange UNI2276 DN 125	2
48	4022200212	OR 2162	2	105	4026904003	Plug 1"	2
49	4022200235	OR 4325	2	106	4026904300	Venting valve 1/4"	4
50	4022216915	Water pump mech. seal	1	107	4026905002	Plug 1/4"	4
51	4022300001	Nylon filter Ø 6	1	108	4026910004	Oil tank plug 1"	1
52	4023100060	Bearing 6211/C3	1	109	1642003500	Mech. transmission cover	1
53	4023100516	Bearing 6004 RS1	2	110	1642003600	Hydr. transmission cover	1
54	4023110070	Bearing 2211 NU ECP/C3	1				
55	4023130050	Bushing 65x55x28 IR	1				
56	4024250000	Oil pump 4 outlets CW	1				

5.4 Part list layout

Mod. PR 250

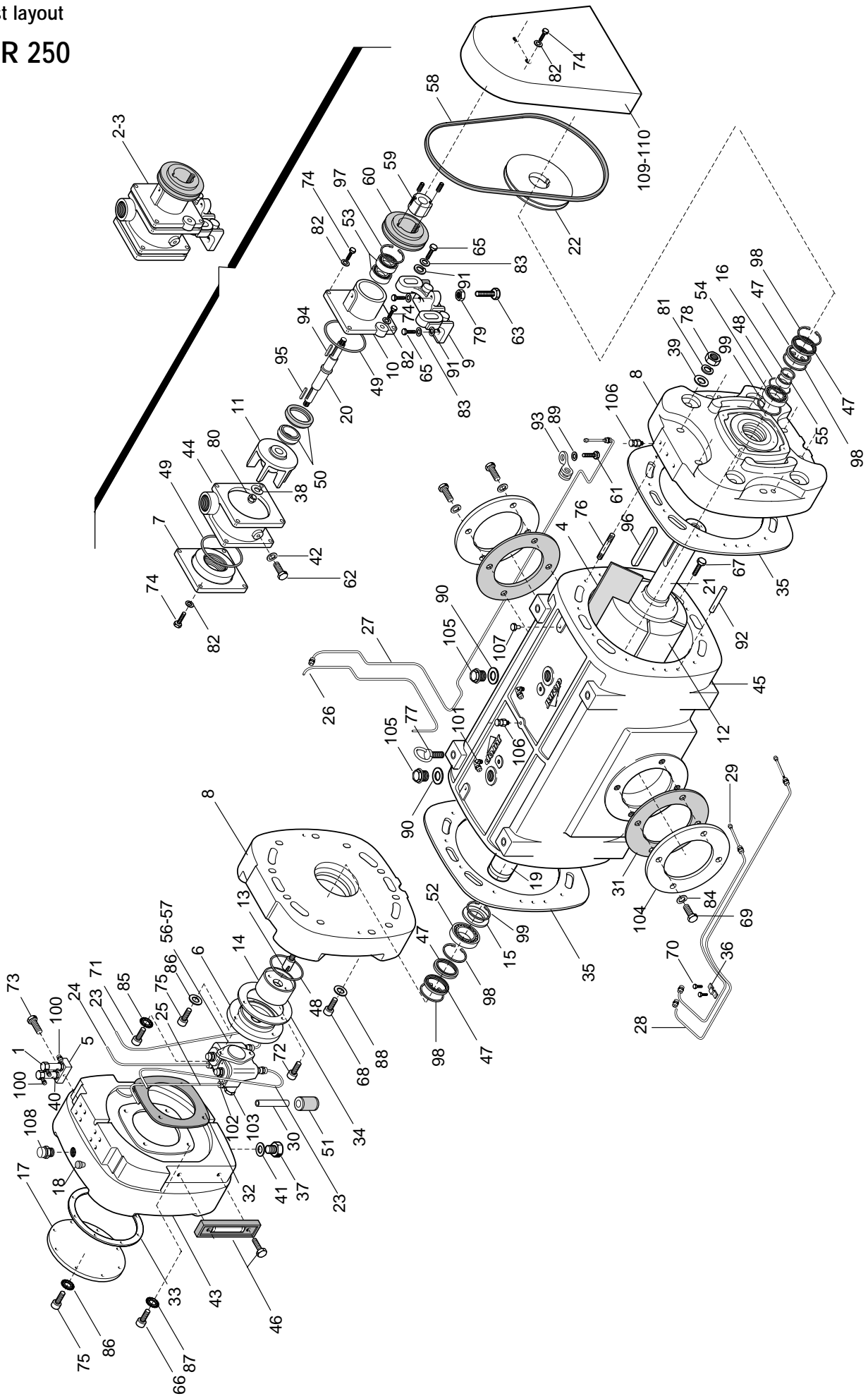

Part list mod. PR 250

Pos.	Code	Description	Qty	Pos.	Code	Description	Qty
1	1401200700	Drip oiler	4	57	4024250500	Oil pump 4 outlets CCW	1
2	1407200800	Water recycling pump cw	1	58	4025350024	Belt SPZ 1060 texrope	1
3	1407200900	Water recycling pump ccw	1	59	4025422300	Cone bushing 2820 Ø 16	1
4	1601605100	Vane PR250	6	60	4025422402	Pulley SPZ 71x1	1
5	1608100600	Oil block	2	61	4026101301	Screw 4.8 M 6x10	1
6	1610015000	Oil pump flange	1	62	4026101403	Screw 4.8 M 8x10	1
7	1610506500	Water pump rear flange	1	63	4026102914	Screw 8.8 M 10x60	1
8	1610506600	End plate	2	65	4026107214	Screw 8.8 M 10x40 5739	4
9	1613500900	Water pump support bracket	1	66	4026107311	Screw 8.8 M 12x30 5739	4
10	1613501000	Water pump front flange	1	67	4026107312	Screw 8.8 M 12x35 5739	12
11	1621502800	Water pump impeller	1	68	4026107306	Screw 8.8 M 12x16	4
12	1621503000	Vacuum pump PR 250 rotor	1	69	4026107514	Screw 8.8 M 16x40	8
13	1622004100	Oil pump pivot	1	70	4026120100	Screw 8.8 M 4x8	2
14	1624009600	Oil pump drive bushing	1	71	4026120300	Screw 8.8 M 6x14 5931	2
15	1624009700	Spacer 100x84x3,9	1	72	4026120303	Screw 8.8 M 6x20 5931	2
16	1624010300	Spacer 65x55x10	1	73	4026120306	Screw 8.8 M 6x30	2
17	1640100800	Oil tank lid	1	74	4026120401	Screw 8.8 M 8x16	10
18	1642600000	Oil line protection	4	75	4026120403	Screw 8.8 M 8x20 5931	11
19	1650006800	Rear shaft PR200/PR250	1	76	4026171211	Stud screw 8.8 M 12x80	20
20	1650009700	Water pump shaft	1	77	4026190002	Eye bolt M 16	2
21	1650010700	Front shaft PR200/PR250	1	78	4026301603	Nut M12 5587	20
22	1653502000	Water pump pulley SPZ 180x1	1	79	4026308006	Nut M10 5588	1
23	1663030400	Oil line pump/drip oiler	2	80	4026322106	Nut M12 sp.	1
24	1663030600	Oil line pump/drip oiler	1	81	4026350508	Grower washer 12	20
25	1663030700	Oil line pump/drip oiler	1	82	4026350505	Grower washer 8	10
26	1663030800	Oil line rear bearing	1	83	4026350608	Grower washer 10 1751	4
27	1663031200	Oil line front bearing	1	84	4026350611	Grower washer 16 1751	8
28	1663031300	Oil line housing front	1	85	4026350908	Washer M 6 6798	2
29	1663031400	Oil line housing rear	1	86	4026350909	Washer M 8 6798	11
30	1663031500	Oil line suction pipe Ø 6	1	87	4026350911	Washer M 12	4
31	1680604800	Inlet/outlet gasket	2	88	4026356107	Flat washer M 12	4
32	1680607100	Oil tank gasket	1	89	4026357003	Flat washer M 6	1
33	1680705600	Oil lid gasket	1	90	4026359001	Washer 40x33,5x1,5 AL	3
34	1680705700	Oil pump flange gasket	1	91	4026356106	Flat washer M 10	4
35	1680705800	Housing gasket	2	92	4026401812	Pin 10x60 M 6	4
36	1682000800	Pipeline fixing strip	1	93	4026426703	Rubber strip Ø 6,5	1
37	1684000000	Oil draining tap 3/8"	1	94	4026500605	Tab 5x5x18	1
38	1685002400	Safety washer	1	95	4026500609	Tab 5x5x28	1
39	1685002700	Washer 35x13x6	20	96	4026501212	Tab 16x10x110	1
40	1685100000	Drip oiler washer AL 14x20x1,5	4	97	4026510525	Seeger ring I 42 7437	1
41	1685100200	Flat washer AL 17x22x1,5	1	98	4026510547	Seeger ring I 90 7437	4
42	1685100800	Washer Ø 8 AL	1	99	4026510551	Seeger ring I 100 7437	2
43	1687100800	Oil tank	1	100	4026702000	Univ. connection 4x1/8" 1050	12
44	1687504500	Water pump housing	1	101	4026706001	Univ. connection 90° 4x1/4" 1020	2
45	1687504600	PR 250 housing	1	102	4026706101	Pivot connection 4x1/8" 1170	2
46	4022106001	Oil sight glass	2	103	4026706104	Pivot connection 6x1/8" 1170	1
47	4022200072	Seal ring 65x90x10	4	104	4026713008	Inlet/outlet flange UNI2276 DN 125	2
48	4022200212	OR 2162	2	105	4026904003	Plug 1"	2
49	4022200235	OR 4325	2	106	4026904300	Venting valve 1/4"	4
50	4022216915	Water pump mech. seal	1	107	4026905002	Plug 1/4"	4
51	4022300001	Nylon filter Ø 6	1	108	4026910004	Oil tank plug 1"	1
52	4023100060	Bearing 6211/C3	1	109	1642003500	Mech. transmission cover	1
53	4023100516	Bearing 6004 RS1	2	110	1642003600	Hydr. transmission cover	1
54	4023110070	Bearing 2211 NU ECP/C3	1				
55	4023130050	Bushing 65x55x28 IR	1				
56	4024250000	Oil pump 4 outlets CW	1				



Jurop spa

Via Crosera, 50
33082 Azzano Decimo/PN · Italy

Telefono ++39 · 434 / 636811

Telefax ++39 · 434 / 636812

<http://www.juop.it>

e-mail: info@juop.it

Juop s.p.a. si riserva di apportare senza preavviso eventuali modifiche ai prodotti descritti.

Juop s.p.a. reserves the right of modifyng the products described above without notice.

Die Firma Jurop s.p.a. behält sich das Recht vor, Änderungen an den o.g. Geräten ohne Voranmeldung anzubringen.

La Société Jurop s.p.a. se réserve le droit de modifier à tout moment et sans préavis les produits illustrés ci-dessus.