

PNR72 VACUUM PUMP



PN SERIES VACUUM PUMPS



FEATURES:

- 254 CFM @ FREE AIR
- 18" CONTINUOUS DUTY
- INJECTION COOLED
- AUTOMATIC LUBRICATION
- HEAT RESISTANT KEVLAR VANES

PNR72 SPECIFICATIONS

RPM Range	800-1000	Horsepower	15
Max Vacuum	27.9" / 93%	Noise @ 18"	78 dB
Max. Cont. Vac.	18" / 60%	Oil Tank Cap.	2.32 qt
CFM @ Free Air	254	Net Weight	300 lbs
CFM @ 18"	233	Rec. Oil	ISO 150
Max Pressure	30 PSI	1 3/8" Smooth Shaft	
		Two 3" Swivel Elbows	

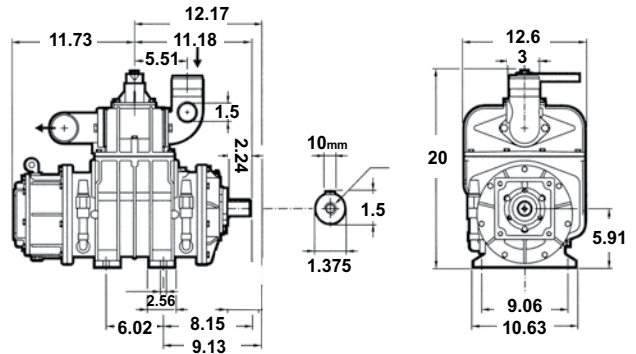

PART #	DESCRIPTION
PNR72	Jurop PNR72 Vacuum Pump

JUROP PNR SERIES PUMPS OPERATING INSTRUCTIONS



1. Be sure to check the vacuum pump for signs of any shipping damage.
2. Be Sure to rotate the rotor shaft on the vacuum pump to insure that it can be rotated by hand. Rotation of pump can be cw or ccw. Please make sure to operate the vacuum pump in the correct direction. Pump operating speed is between 800 & 1000 RPM.
3. For maximum pump life and performance, we recommend the use of proper compatible components to protect your pump. These include primary and secondary shutoffs, oil catch mufflers and final filters.
4. Pump is shipped without oil. Place 2 1/2 to 3 quarts of ISO 150 wt. non-detergent oil in the oil reservoir. A dip stick is provided on the pump to check the proper oil level.
5. The pump is equipped with an automatic forced lubrication system. The volumetric oil pump with variable flow injects the lubricating oil directly inside the oil pump, therefore eliminating a manual adjustment of the oilers. This results in a lower oil consumption and makes adjustment to oilers unnecessary.
6. Be sure and grease the front flange bearing. A grease fitting is provided on top of the front flange on the front of the pump.
7. We recommend the use of oil resistant hose on both the inlet and outlet sides of the vacuum pump. The vacuum pump with the standard two port manifold can be connected to the tank by either the front or rear air port.
8. We recommend periodic cleaning of your pump. To do this, remove the suction line from the vacuum pump, move the suction valve to neutral, run the pump at an idle, and pour one pint of diesel fuel into the housing of the pump. Allow the pump to run for a short time. Finally, move the suction valve to vacuum to blow out the diesel fuel and dirt.

www.chandlerequipment.com

Due to unforeseeable market fluctuations, prices are subject to change without notice.

