

## PNR102 SPECIFICATIONS

RPM Range	<b>800-1000</b>	Horsepower	<b>22</b>
Max Vacuum	<b>27.6" / 92%</b>	Noise @ 18"	<b>78 dB</b>
Max. Cont. Vac.	<b>18" / 60%</b>	Oil Tank Cap.	<b>2.38 qt</b>
CFM @ Free Air	<b>360</b>	Net Weight	<b>381 lbs</b>
CFM @ 18"	<b>332</b>	Rec. Oil	<b>ISO 150</b>
Max Pressure	<b>30 PSI</b>	1 3/8" Smooth Shaft	
		Two 3" or 4" Swivel Elbows	

## FEATURES:

- 360 CFM @ FREE AIR
- 18" CONTINUOUS DUTY
- INJECTION COOLED
- AUTOMATIC LUBRICATION
- HEAT RESISTANT KEVLAR VANES

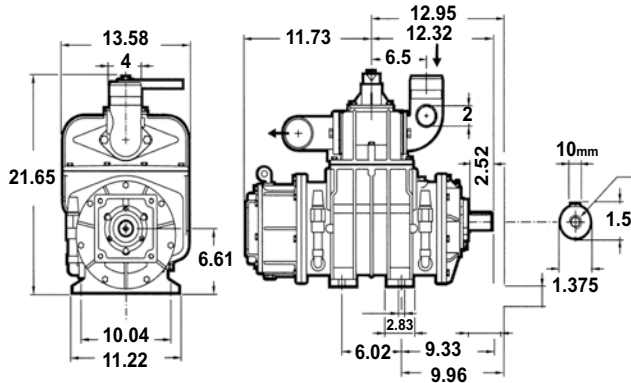

PART #	DESCRIPTION
PNR102	Jurop PNR102 Vacuum Pump
-	Atex Certified PNR102 Vacuum Pump

# PNR102 JURO-PAK

**JUROP PNR102 Vacuum Pump** combined with a state of the art Gearbox Auto Alignment and Shutoff-Filter System complete with powder coating and assembly.

## FEATURES:

- **JUROP PNR102 VACUUM PUMP**
- **PUMP MOUNTING STAND MADE OF 3/8" HEAVY DUTY STEEL**
- **ALUMINUM AUTO ALIGN BRACKET**
- **3 SHAFT GEARBOX, 400 SERIES WITH 1 1/4" SHAFT**
- **1 3/8" X 1 1/4" SIZE 9 PUMP COUPLING**
- **10 GALLON HORIZONTAL SECONDARY WITH 3" OPENING**
- **FINAL FILTER 3" WITH "REUSABLE" 55 MESH FILTER**
- **VACUUM PRESSURE TREE WITH 2" BRASS PRESSURE RELIEF VALVE, 1 1/2" BRASS VACUUM RELIEF VALVE & 2 1/2" LIQUID FILLED VACUUM PRESSURE GAUGE**
- **POWDER COATING & ASSEMBLY**

