

LC300 CONTENDER VACUUM PUMP



LC300 VACUUM PUMP



FEATURES:

- 300 CFM @ FREE AIR
- 24" CONTINUOUS DUTY
- LIQUID COOLED
- AUTOMATIC LUBRICATION
- INDEPENDENT SIDE MOUNTED OIL TANK
- HEAT RESISTANT KEVLAR VANES

LC300 SPECIFICATIONS

RPM Range	900-1100	Noise @ 18"	70-73 dB
Max Vacuum	27" / 90%	Oil Tank Cap.	4.23 qt
Max Cont. Vac.	24" / 83%	Net Weight	430 lbs
CFM @ Free Air	300	Rec. Oil	ISO 150
CFM @ 18"	226	1 3/8" Smooth Shaft	
Max Pressure	30 PSI	Two 3" Swivel Elbows	
Horsepower	17	Water Cooled (9 GPM Req'd)	

PART #	DESCRIPTION
LC300	Jurop LC300 Vacuum Pump

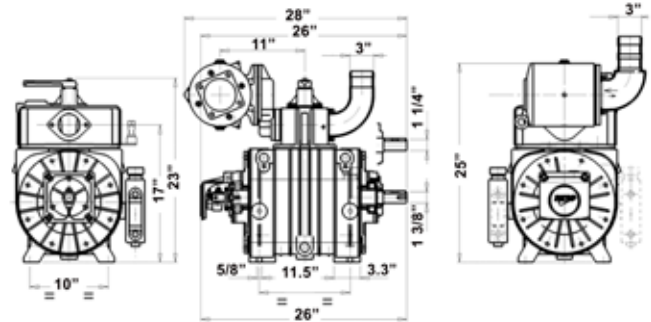

For filter assembly, add either:
 CEI Filter 1007-1003
 Jurop Filter 185219N7B0

LC300 JURO-PAK

JUROP LC300 Vacuum Pump combined with a state of the art Gearbox Auto Alignment and Shutoff-Filter System complete with powder coating and assembly.

FEATURES:

- **JUROP LC300 VACUUM PUMP**
- **PUMP MOUNTING STAND MADE OF 3/8" HEAVY DUTY STEEL**
- **ALUMINUM AUTO ALIGN BRACKET**
- **3 SHAFT GEARBOX, 400 SERIES WITH 1 1/4" SHAFT**
- **1 3/8" X 1 1/4" SIZE 9 PUMP COUPLING**
- **10 GALLON HORIZONTAL SECONDARY WITH 3" OPENING**
- **FINAL FILTER 3" WITH "REUSABLE" 55 MESH FILTER**
- **VACUUM PRESSURE TREE WITH 2" BRASS PRESSURE RELIEF VALVE, 1 1/2" BRASS VACUUM RELIEF VALVE & 2 1/2" LIQUID**
- **POWDER COATING & ASSEMBLY**

LC300 JURO-PAK
PART # 1004-0300

HYDRAULIC LC300 JURO-PAK
PART # 1004-0300-HYD

LC300 RAZOR-PAK
PART # 1004-0300-RAZ



www.chandlerequipment.com

Due to unforeseeable market fluctuations, prices are subject to change without notice.

