

*Performance by Design*

***Conde' Pumps***

**PUMP OWNERS MANUAL**

**ProVac 3 PUMP**

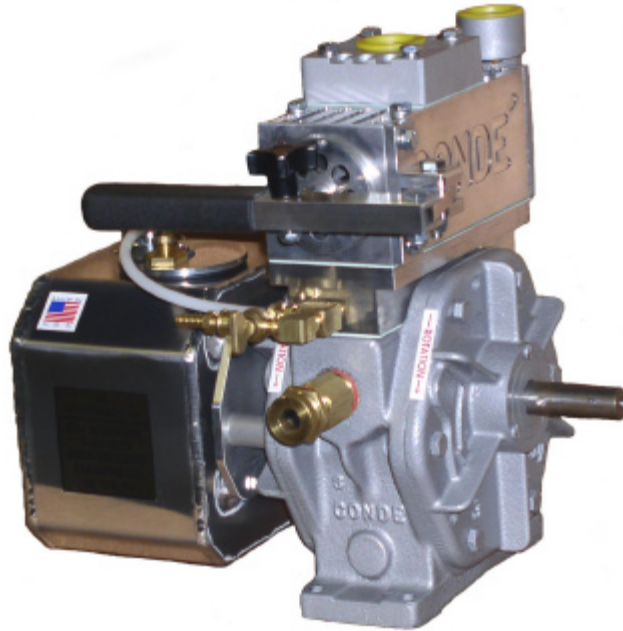

***Westmoor, Ltd.***

P.O. Box 99, 906 West Hamilton Avenue  
Sherrill, New York 13461

**Phone:**

**800-367-0972**

**Fax:**

**315-363-0193**

**E-mail**

**[pumps@westmoorltd.com](mailto:pumps@westmoorltd.com)**

## INITIAL START UP OF ProVac 3 PUMP

Congratulations on your purchase of a Conde ProVac 3 pump. You have selected the finest and most innovative vacuum pump available. Conde designs and builds pumps for long life, durability and ease of use.

### SAFETY INFORMATION

**WARNING:** The vacuum pump has rotating parts. Keep guards in place. Never operate the pump with the guards removed.

**WARNING:** The vacuum pump may reach temperatures above 200 degrees F during extended or severe duty operation. Allow to cool before servicing.

**CAUTION:** Never operate without oil. Failure to properly lubricate the pump will cause premature failure.

**CAUTION:** The pump will discharge oil from the exhaust port. Connect the exhaust port to an adequate oil recovery system.

### IMPORTANT

Vacuum relief valves have NOT been pre-set.  
(These should both be adjusted after the pump is installed)  
To adjust vacuum relief valve

- 1) If the pump is equipped with the slide valve diverter valve, pull the handle out to engage in the vacuum mode.
- 2) Close all openings in the vacuum system.
- 3) Start pump.
- 4) Loosen jam lock nut on top of the relief valve.
- 5) Under the jam nut is the adjustment nut. Turn nut clockwise to increase vacuum, turn counter-clockwise to decrease vacuum.
- 6) After desired vacuum is reached, re-tighten jam lock nut.

**CAUTION: DO NOT EXCEED 20" HG FOR CONTINUOUS OPERATION**

### CONDE WICK OILING SYSTEM

All Conde ProVac 3 pumps are equipped with the trouble free and adjustment free Conde Wick Oiling System. The Conde Wick system has been engineered to provide constant oiling to your vacuum pump under all operating conditions. There is never any need for adjustment of any kind. No more fooling with tricky drip oilers.

Before operating your pump, fill the oil reservoir with a premium quality 10W-30 grade high detergent **synthetic** motor oil. **After taking delivery of your pump, make sure that the oil reservoir is filled. Pumps are not shipped with oil in the reservoir.** Fill the tank until it is just below

The level of the tank jets in the inside of the reservoir. All tank oilers are equipped with a sight glass to determine the oil level inside the tank.

## OIL RECOMMENDATIONS

Use high detergent 10W-30 motor oil only. ***Synthetic oil is highly recommended and will extend the life of your pump.*** Using the proper type and weight oil is essential for long life and trouble free operation. Using the wrong oil or dirty oil can cause loss of vacuum or pump failure. ***Never run the pump without oil in the tank oiler. Running the pump without oil in the reservoir will cause pump failure!***

Changing the oil is not necessary since the oil is discharged from the pump and should be properly disposed of.

Check the oil level daily or every 8 hours of operation.

Any oil catch devices used with the pump unit should be periodically drained to avoid oil being blown out the exhaust. **This used oil should not be re-used.**

## GENERAL MAINTENANCE

If pump is pulley driven, adjust belt to 1/2" of free play at center of the pulleys. Make the first adjustment after the first 24 hours of operation. Make any additional adjustments when necessary.

Generally, the only maintenance required on the ProVac 3 vacuum pump, is to maintain oil in the oil reservoir. It is imperative that the pump is always getting the proper supply of oil. Periodically or at least once a week, visually look at the window in the oil dripper, or the wick oiler oil tube, to make sure the proper amount of oil is being drawn into the pump. If no oil is being sucked into the pump, immediately turn the pump off. Please refer to the trouble shooting section of this manual for more information on correcting the problem.

The pump should be isolated from any contaminants so that no foreign substance or moisture can enter the pump. However, if anything is inadvertently sucked into the pump, the pump should be flushed immediately to remove all contaminants. If it is not immediately flushed, rust can form inside the pump which can, in turn, cause pump failure.

## FLUSHING INSTRUCTIONS

It may be necessary to flush your pump to remove and gum or varnish buildup inside the pump that causes the vanes to stick inside their slots. This is a simple maintenance operation and should be the first step when troubleshooting a loss of vacuum in a system. **Before starting, be sure the exhaust from the oil catching devise (oil catch muffler) is directed away from the motor or engine and any other hot surfaces).** Open the flush valve on ProVac 3 model and insert a tube into it. On vacuum only models, detach the oil tube from its connection to the oil tank. Use kerosene or diesel fuel for flushing. **NEVER USE GASOLINE OR OTHER HIGHLY FLAMMABLE LIQUID FOR FLUSHING.** While the pump is running under vacuum (slide valve in out position on HD models), simply insert the other end of the tube into the cleaning fluid and allow the pump to draw the fluid in. If there is no vacuum present, disconnect the air hose from the top of the slide valve on HD models, or disconnect the intake hose to the tank on vacuum only models, and pour a couple of ounces of cleaning fluid in. Alternately, let air into the tube in the cleaning solution. It can take up to a quart of cleaning solution to flush out a pump. When flushing is complete, draw about five ounces of oil into the pump in the same manner. This completes the flushing process. Remove the tube from the flush valve and close it on the HD models, or reattach the oil tube to the tank oiler on vacuum only models. Finally, reconnect any hoses that were disconnected.

On badly gummed up pumps it may be necessary to pour a large quantity of cleaning fluid into the pump (enough to fill the entire pump) and let it sit over night. Be careful to drain as much of the cleaning fluid as possible out of the pump before attempting to turn the pump on.

## STORAGE OF VACUUM PUMPS

Disconnect air lines and pump fittings from the intake and exhaust ports of the air pump. Then open the flush valve and pour about five ounces of oil into it. Turn the rotor shaft by hand a few times to coat the inside of the pump housing with oil. Close the flush valve and fill the oil tank with oil. Plug the pump ports with commercial pipe plugs or the plastic plugs that were supplied with the unit. Coat the shaft with a small amount of grease or oil to prevent rust buildup during storage. Store the air pump in a cool, dry place.

**IMPORTANT** – When RE-STARTING the air pump after storage, turn the pump over by hand to be sure the shaft and rotor assembly spins freely within the pump housing. If any binding or restriction is felt, the pump must be taken apart and cleaned.

## SLIDE VALVE OPERATION

The Conde Slide Valve is a unique changeover valve developed by Conde Pumps to enable the vacuum pump to be switched from vacuum to pressure mode. This is accomplished by simply pulling out the slide valve handle (vacuum mode) or pushing in the handle (pressure mode). The Conde Slide Valve also has a built in check valve to hold tank vacuum even when the pump is turned off.

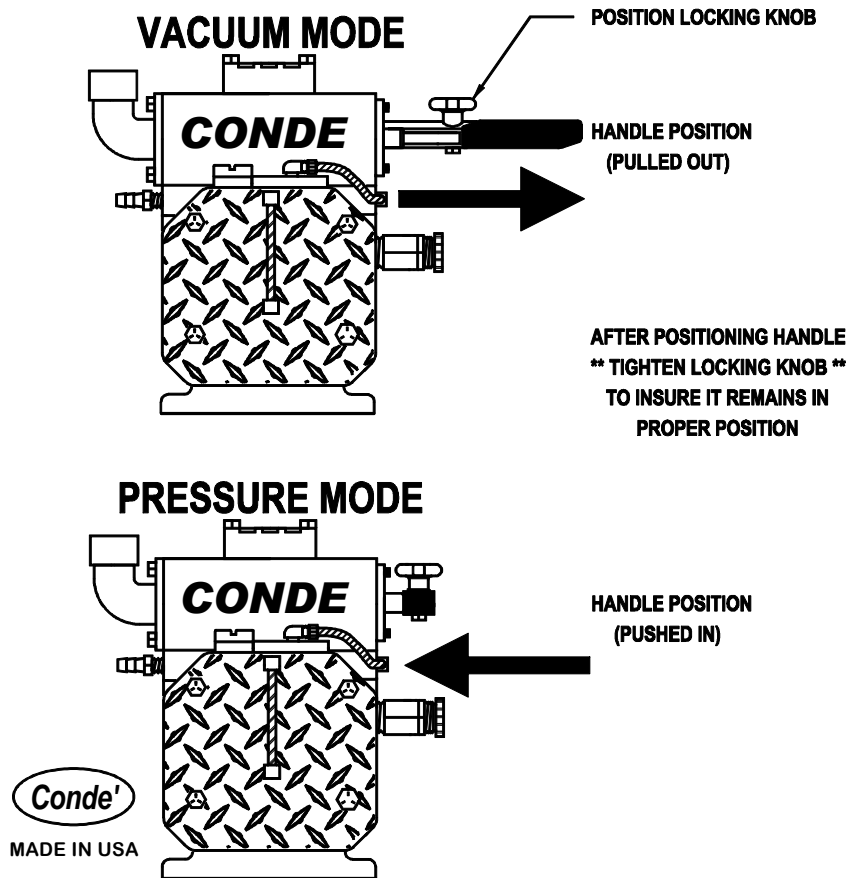

# CONDE ProVac 3 DISASSEMBLY & ASSEMBLY

## TOOLS REQUIRED:

Flathead Screwdriver

1/2" Wrench

9/16" Wrench

Hammer

Rubber Mallet

Fine File

Tool Kit (Optional) Includes: Shaft Collar, Endplate Removal Bolts, Bearing Installation Tool.

## Disassembly

- 1) If pump is HD model, remove the slide valve first by:
  - a) Detach the oil lines from the pump to the oil reservoir.
  - b) Remove the four bolts from the top to the slide valve and lift off.
  - c) Remove gasket under the Slide Valve.
- 2) Remove the tank oiler (if attached to the pump).
- 3) Remove all endplate hex screws and all twelve bearing cover screws.
- 4) Remove both bearing covers, and all shims.
- 5) Slide the shaft collar (from tool kit) over shaft and tighten screw very securely. Use the fan set hole to help collar from sliding.
- 6) Grease the ends of the bolts (from tool kit) and screw them into the three threaded holes located in the endplate on the opposite side of the pump that the collar is on. Turn the bolts alternating with no more than one turn at a time until endplate slides off the rotor shaft.
- 7) Remove the bearing and oil seal from the endplate.
- 8) Put the plate just removed back in place without bearing, then slide the collar over the shaft and tighten very securely using the fan set hole.
- 9) Remove the opposite endplate using the 3 bolts as previously done.
- 11) Remove the bearing and oil seal from the endplate.
- 12) Remove the rotor and vanes from the rotor.

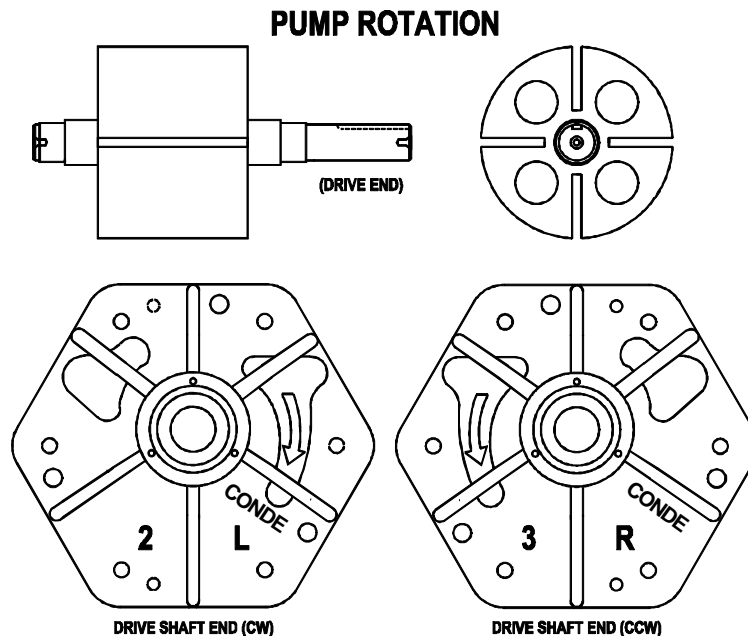

**PUMP ROTATION IS DETERMINED WHEN ASSEMBLED**  
**ASSEMBLE WITH DRIVE END THRU - 2L PLATE - FOR (CW) ROTATION**  
**ASSEMBLE WITH DRIVE END THRU - 3R PLATE - FOR (CCW) ROTATION**

## ASSEMBLY

NOTE: Refer to exploded parts diagrams towards end of manual for additional guidance on how parts are oriented on pump and slide valve. Assemble the pump in a vertical position. This will align the rotor with the endplates and the housing.

- 1) De-burr all parts with a fine file, especially where endplate removal bolts were digging into housing.
- 2) Determine correct rotor rotation (refer to drawing on previous page). Apply a few drops of oil to the vanes and check the vane slots for free movement. Set the vanes aside.
- 3) Start assembly with the end plate that has the dowel pin holes on the right side. (NOTE: the dowel pins are always on the exhaust side of the pump). This will be the CCW endplate. Press the oil seal in place.
- 4) Insert rotor into housing according to rotor rotation. (The pump must be assembled in the same position as it was disassembled. The rotation can not be changed). Assemble the air pump in a vertical position. This will align the rotor with the endplates and housing. Position housing gasket and install the endplate on the housing with the six hex bolts and tighten snugly. Drive the two dowel pins in place and then tighten hex screws securely.
- 5) Press bearing on the shaft using a bearing installation tool (from tool kit) or an arbor press. **IMPORTANT:** press on the inner race of bearing only. Pressing on the plastic seal may cause damage to roller bearings.
- 6) Invert pump assembly and install the vanes in the slots.
- 7) Press the shaft seal in place on the remaining endplate. Insert dowel pins and place a paper gasket in position on the housing. Install the endplate with the hex bolts and tighten securely.
- 8) Press bearing onto shaft as previously done.
- 9) Shim the pump as follows: First of all, turn rotor by hand to get a "feel" of how it turns when not binding on the endplates. With rubber mallet, hit one end of the rotor shaft to push rotor against opposite endplate. Insert shims and bearing cover on the side with the shaft you hit. Add enough shims so that the cover is flush with the endplate. Screw in bearing cover screws.  
Turn pump by hand, and if rotor feels like it is not binding at all, add more shims until a slight binding is felt. Once this is done, remove .002" of shims, and then set the remainder aside, along with the bearing cover. Now, hit the other end of the rotor shaft and repeat process of adding shims until binding occurs. Remove .002" of these shims and re-install bearing cover with all screws. Install shims and bearing cover on other side that were previously set aside. Now turn pump over by hand. **IMPORTANT:** The pump should spin freely by hand when completed. If any binding occurs, repeat above process.
- 10) Reinstall oiler tubes.
- 11) If pump is a ProVac 3 HD model, reassemble the Slide Valve by:
  - a) Place gasket(s) on pump housing.
  - b) Place Slide Valve housing on gasket, making sure that the check valve flapper assembly is properly seated.
  - c) Screw in the four mounting bolts on the Slide Valve. Do not over tighten bolts.

## TROUBLE SHOOTING YOUR PUMP

PROBLEM	CAUSE	SOLUTION
Loss of pump performance	Slide Valve not all the way pushed in or out.	Put slide valve all the way in appropriate position. Tighten handle nut if valve moves during operation.
	A ball trap is stopping air flow	Drain ball trap and/or empty tank.
	Air filter and/or strainer are plugged up.	Check the filter and/or screens. Clean or replace if necessary.
	A valve is open that should be closed.	Check all valves for correct position. Make sure flush valve is closed.
	Plumbing and/or various other attachments are loose.	Tighten all plumbing and anything else connected to the system.
	Motor is running too slow.	Adjust throttle so that the pumps are running between 1200-1750 rpm.
	Belt is slipping due to lack of tension on belt.	Adjust motor base to allow for 1/2" of free play at center of pulleys.
	Relief valves are faulty.	Check relief valves and reset if necessary.
	One or more pump vane is sticking or is worn.	Flush out pump and replace vanes if necessary.
	Piston cups inside of slide valve are worn out.	Install new piston cups.
Unusual Noises using a	Pulley is not secure to shaft.	Re-secure the pulley to shaft using set hole.
	Blockage within plumbing.	Locate and remove the substance causing blockage within plumbing.
	Pulleys not in alignment.	Loosen pulleys and align straight edge.
	Pulley, fan or fan guard is not properly secured.	Re-secure properly.
	Leak in system.	Check all connections for leaks.
	One or more pump vane is sticking.	Flush out pump and replace vanes if necessary.

## PUMP DRIVE CONSIDERATIONS

Conde ProVac 3 pumps can be belt driven or direct driven with couplings from gasoline or diesel engines, electric motors, PTO drives, or hydraulic motors.

### BELT DRIVE SYSTEMS

Pulley combinations should be chosen so that pumps run within the specified speed range. The Conde ProVac 3 is made to operate between 1000 and 1750 rpm. Pulleys should be specified that have adequate "belt wrap" so that maximum contact of belt to pulley can be achieved and minimize the chance of damage to the pump by over-tightening the belt(s). Please contact Westmoor, Ltd. For information on proper pulley combinations and belt sizes for your Super model and application. Always leave about 1/2" of belt play when adjusting the belt. Over-tightening the belt can damage the pump and not enough tension can cause belt slip and loss of pump performance.

### DIRECT DRIVE COUPLINGS

We recommend Lovejoy type couplings with a flexible rubber "spider" between the pump mounted flange and the motor mounted flange. Couplings must be carefully aligned per the manufacturer's specifications. A small straight edge and set of feeler gauges should be used to insure that the coupling is aligned properly. Call Westmoor, Ltd. to determine which model coupling is correct for your pump and application.

## INSTALLATION COMPONENTS FOR ProVac 3 PUMPS

Use the diagram as a guide for plumbing your liquid waste tank system. Please contact factory if you have any questions or need further assistance.

**OIL CATCH MUFFLER:** An oil catching device should be part of the pump system. The vacuum pump exhaust should be connected to the oil catch device (on slide valve models, connect to the side valve body opposite the handle). The pressure relief vent should also be plumbed to the oil catch device since oil from inside the pump will exhaust out the pressure vent.

**VACUUM RELIEF VALVE:** A vacuum relief valve is built into the pump manifold on ProVac 3 HD model. A vacuum relief valve should be installed all other models on the tank.

**PRESSURE RELIEF VALVE:** As a safety precaution, an additional pressure relief valve should be installed on the tank for slide valve models. **CAUTION: NEVER EXCEED 10 PSI ON NON-CODED TANKS.**

**VACUUM GAUGE:** A vacuum gauge installed as shown is essential to make sure vacuum levels are correct. Th gauge is also essential for trouble shooting.

**PRIMARY SHUTOFF:** A primary shut-off should be installed in the tank to close off the vacuum line to the pump when the tank is full. The primary trap prevents liquids from entering the pump.

**SECONDARY MOISTURE TRAP:** The secondary trap spins air to separate moisture out of the air. It will also shut off the vacuum line in the event that the primary shut-off fails



# #3 PRO-VAC TYPICAL TANK SET UP

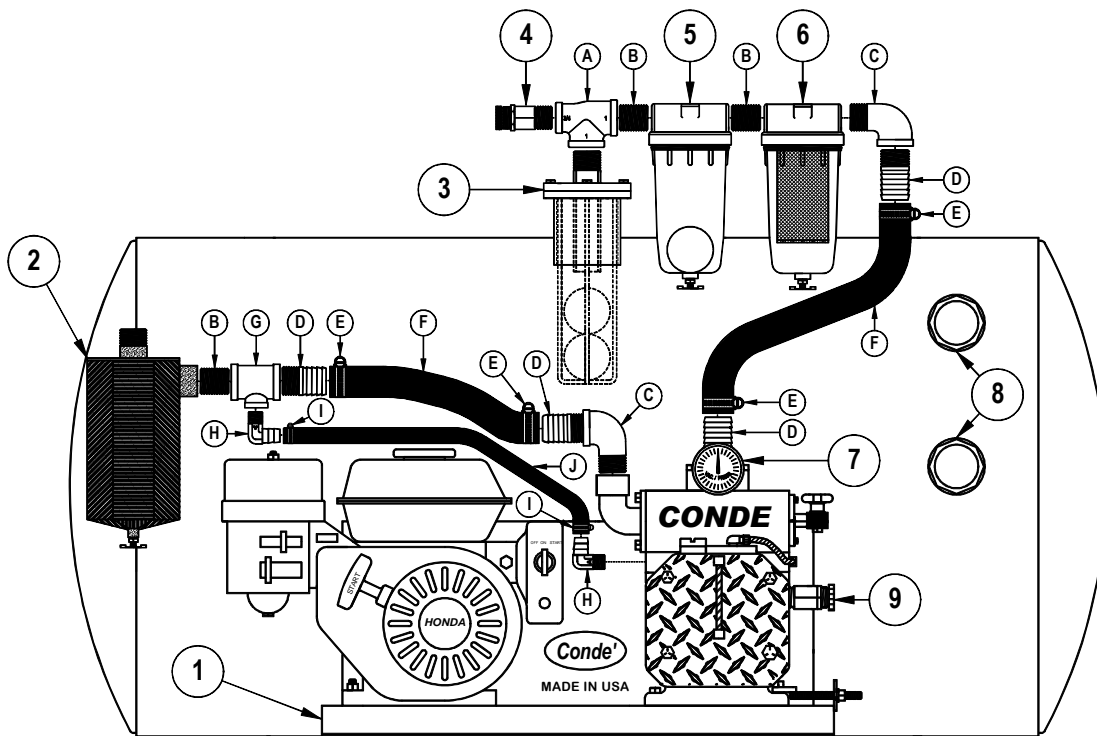

ITEM	QTY	PART NUMBER	COMPONENT DESCRIPTION
1	1 PC	HDUN03PV05ES	#3 PRO-VAC (VAC/PRESS) HONDA 5.5 HP EL. START GAS UNIT
2	1 PC	MFOC3PV	#3 PRO-VAC OIL CATCH MUFFLER (1" FNPT)
3	1 PC	LWTRPV3	#3 PROVAC PRIMARY TRAP (1" MNPT)
4	1 PC	RVP10	BRASS RELIEF VALVE (3/4" MNPT) SPECIFY PRESSURE
5	1 PC	LWTR02	PLASTIC SECONDARY TRAP (1" FNPT)
6	1 PC	LWTRPF02	PLASTIC PRE-FILTER (1" FNPT)
7	1 PC	GAGE016	VACUUM / PRESSURE GAUGE (1/4" MNPT CENTER BACK CONN.)
8	2 PC	LWSG20	2" SIGHT GLASS ASSEMBLY
9	1 PC	RVP10	BRASS RELIEF VALVE (3/4" MNPT) SPECIFY VACUUM

ITEM	QTY	PART NUMBER	PLUMBING / FITTING DESCRIPTION
A	1	PFTB071010	3/4" X 1" X 1" TEE
B	3	PFNB100	1" NPT NIPPLE (SPECIFY LENGTH)
C	2	PFEB5100	1" NPT 90 DEG. STREET ELBOW
D	4	PFBH100125	1" NPT X 1-1/4" MALE HOSE BARB
E	4	CLAMP020	NO. 20 HOSE CLAMP
F	2	HOSELWP114	1-1/4" I.D. VACUUM / PRESSURE RATED HOSE (SPECIFY LENGTH)
G	1	PFTB101008	1" X 1" X 3/8" TEE
H	2	PFBHB9050038	3/8" NPT X 1/2" 90 DEG. MALE HOSE BARB
I	2	CLAMP008	NO. 08 HOSE CLAMP
J	1	HOSEPR050	1/2" I.D. PRESSURE VENT HOSE (SPECIFY LGTH)

# BILL OF MATERIAL #3 PROVAC PUMP

OCTOBER 27, 2008

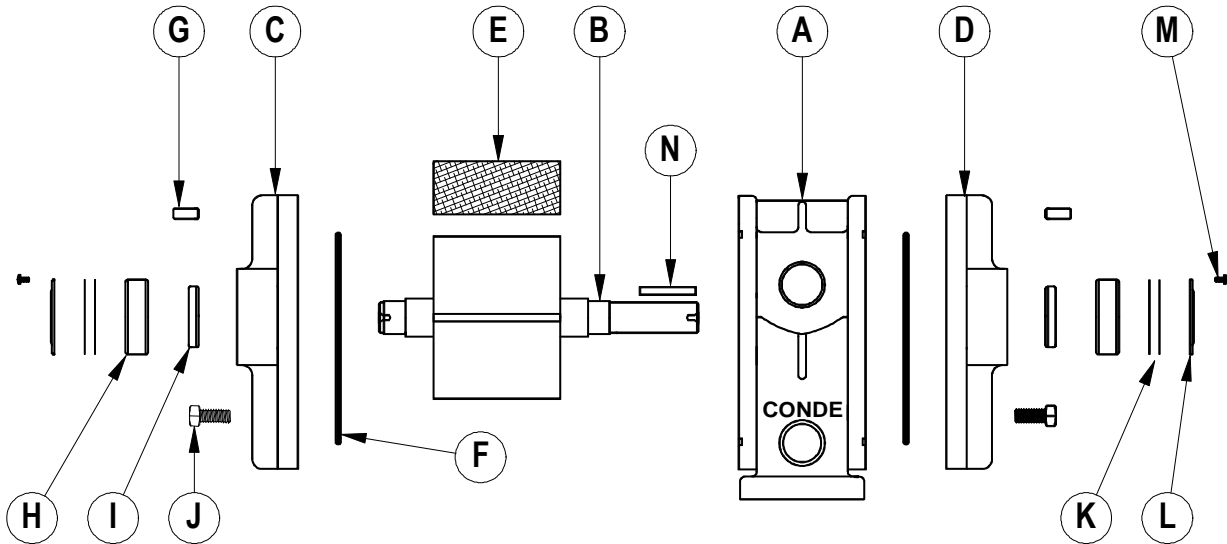

ITEM	QTY	PART NUMBER	DESCRIPTION
A	1	HS03PV	#3 PROVAC HOUSING
B	1	RT03PV	#3 PROVAC ROTOR
C	1	PLF03PV-2L	#3 PROVAC (CW) END PLATE
D	1	PLF03PV-3R	#3 PROVAC (CCW) END PLATE
E	4	VN03FB91PV	#3 PROVAC VANE
F	2	OR159	#3 PROVAC HOUSING O-RING
G	4	PIN3612	1/4" DOWEL PIN
H	2	BR036204A	#3 BEARING
I	2	SE03	#3 OIL SEAL
J	12	FS31075A	5/16" - 18 X 3/4" HEX CAP SCREW
K	1/SET	BRS03	#3 SHIM SET
L	2	BRC03	#3 BEARING COVER
M	1/SET	FS16025	#3 BEARING COVER SCREWS
N	1	KEY03	#3 (3/16" SQ.) SHAFT KEY

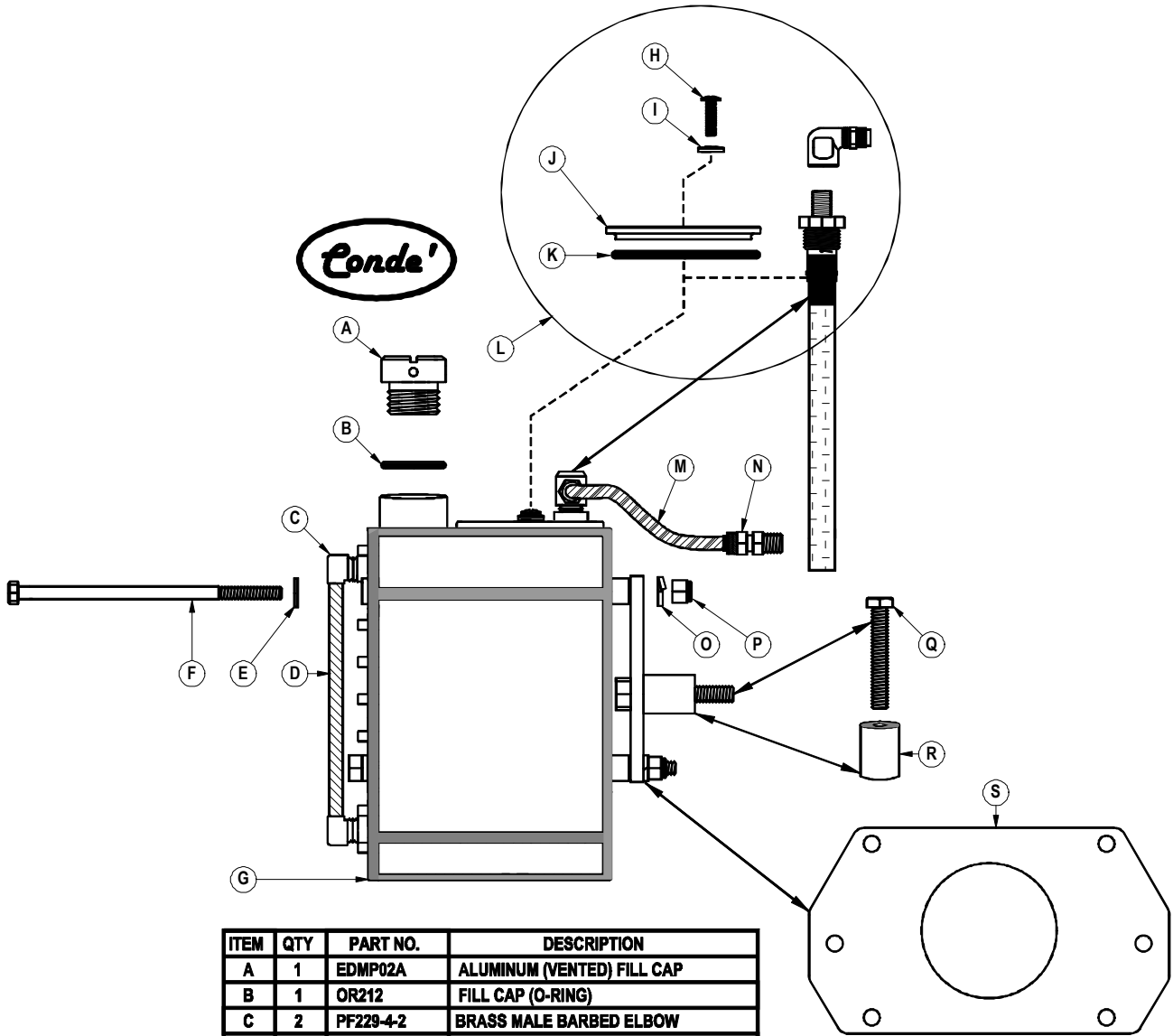

ITEM	QTY	PART NO.	DESCRIPTION
A	1	EDMP02A	ALUMINUM (VENTED) FILL CAP
B	1	OR212	FILL CAP (O-RING)
C	2	PF229-4-2	BRASS MALE BARBED ELBOW
D	1	TO016	1/4" X .040 VINYL (SIGHT TUBE)
E	4	FSW25062	1/4" S.S. FLAT WASHER
F	4	FS25550	1/4-20 X 5-1/2" HEX CAP SCREW
G	1	7TO0612SDS	OIL RESERVOIR BODY (ONLY)
H	1	FSX19075	10-32 X 3/4" S.S. PAN HEAD SCREW
I	1	FSXW19000	#10 SEALING WASHER
J	1	TO007PV	ALUMINUM OIL JET HOLDER (SINGLE)
K	1	OR231	O-RING
L	1	TOTOP3PV	PRO-VAC TANK OILER TOP (COMPLETE)
M	1	RWPATUB025A	1/4" OIL LINE
N	1	PF68P-4-2	POLY-TITE MALE CONNECTOR
O	4	FSW25050A	1/4" LOCK WASHER
P	4	FSN25	1/4-20 ESNA LOCK NUT
Q	2	FS31200C	5/16-18 X 2" TFL HEX CAP SCREW
R	2	TO3PVSP	PRO-VAC MOUNT BRACKET SPACER
S	1	TO3PVSDSMT	OIL RESERVOIR MOUNTING BRACKET

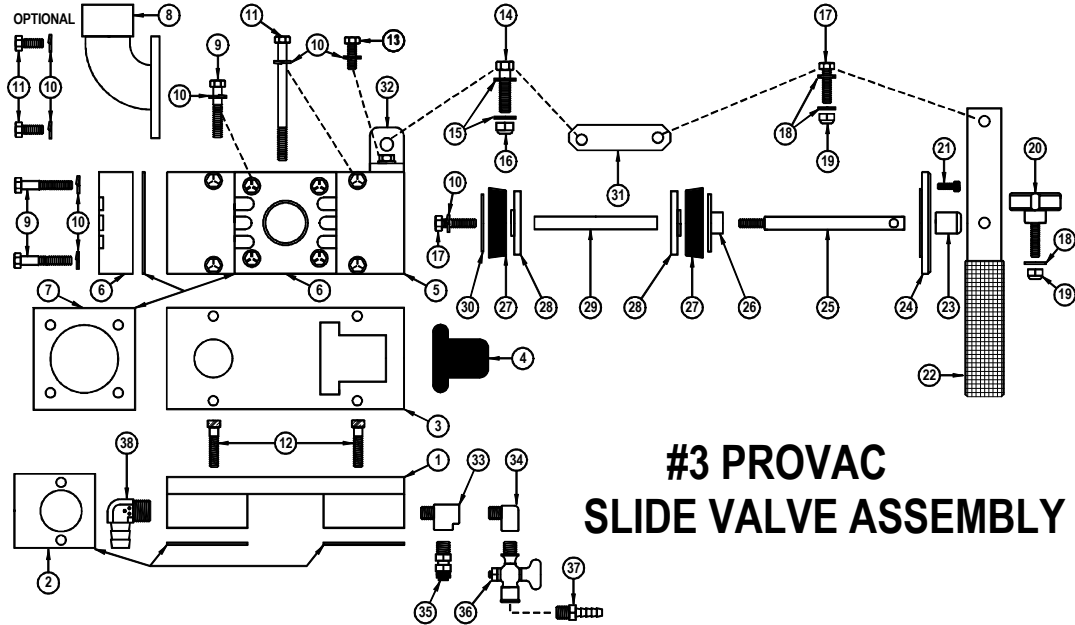

## #3 PROVAC SLIDE VALVE ASSEMBLY

### #3 PROVAC SLIDE VALVE ASSEMBLY BILL OF MATERIAL

ITEM NO.	QTY	PART NO.	DESCRIPTION
1	1	SV003	#3 PROVAC S.V. ADAPTOR MOUNT
2	2	GSKPV03	#3 PROVAC ADAPTOR MOUNT GASKET
3	1	SV03PV	#3 PROVAC S.V. GASKET
4	1	GSKLB03	#3 PROVAC FLAPPER
5	1	SV003D	#3 PROVAC S.V. BODY
6	1 OR 2	SV044	#3 PROVAC 1" ADAPTOR BLOCK
7	2	GSKLB06A	ADAPTOR BLOCK GASKET
8	1	SV044A	#3 PROVAC 1" 90° CONNECTOR
9	4 OR 8	FS25150	1/4 - 20 X 1-1/2" HEX CAP SCREW
10	15	FSXW25050	1/4" LOCK WASHER
11	4	FS25350	1/4 - 20 X 3-1/2" HEX CAP SCREW
12	4	FS25150C	1/4 - 20 X 1-1/2" SOCKET HEAD SCREW
13	2 OR 6	FS25075	1/4 - 20 X 3/4" HEX CAP SCREW
14	1	FS31150	5/16 - 18 X 1-1/2" HEX CAP SCREW
15	2	FSXW31075	5/16" FLAT WASHER
16	1	FSN31A	5/16 -18 ESNA HEX NUT
17	2	FS25100A	1/4 - 20 X 1" HEX CAP SCREW
18	3	FSXW25062	1/4" FLAT WASHER
19	2	FSN25	1/4 - 20 ESNA HEX NUT
20	1	SV005C	POSITION LOCKING KNOB
21	3	FS16050	8-32 X 1/2" SOCKET HEAD SCREW
22	1	SV030C	SLIDE VALVE HANDLE
23	1	SV014A	SLIDE VALVE OUTER SPACER
24	1	SV002B	SLIDE VALVE MUTI HOLE END CAP
25	1	SV001K	PROVAC SLIDE VALVE OUTER ROD
26	1	SV014B	SEALCUP WASHER/SPACER
27	2	SV006C	2" DIA. SEAL/PISTON CUPS
28	2	SV006D	SEAL CUP HUB
29	1	SV001J	PROVAC SLIDE VALVE INNER ROD
30	1	SV006E	SEAL CUP WASHER
31	1	SV0030F	SLIDE VALVE HANDLE LINK
32	1	SV0030E	SLIDE VALVE HANDLE BRACKET
33	1	PF2225P-2	1/8" NPT BRASS STREET TEE
34	1	PF2202P-2-2	1/8" NPT BRASS STREET ELBOW
35	1	PF68P-4-2	POLY-TITE MALE CONNECTOR
36	1	SV124	1/8" BRASS FLUSH VALVE
37	1	TO008	1/8 NPT X 1/4" BRASS BARB
38	1	PFBHB9050038	3/8 NPT X 1/2" BRASS BARB 90°

